

**Solar hot water system installation guide
for flat plate systems.**



table of contents

System Components	2
Introduction	3
Section One:	
General Guidelines and Precautions	4
Section Two:	
Solar thermal system design guidelines	5
Section Three:	
Collector Layout Orientation and Siting	9
Section Four:	
Flat Plate collector installation	
Flat Plate collector Dimensions and Technical Data	11
Flat Plate rack mounting system and shipping contents	12
Flat Plate flush mounting system and shipping contents	15
Flat Plate strut clips mounting system and shipping contents	16
Mounting the collector feet	17
Section Five:	
System Piping	19
System Piping Diagrams	20
Piping single tanks systems	27
Piping two tanks systems	28
Section Six:	
Component Installation	
Tank dimensions and capacities	29
Regusol pumping station installation	30
Controller Installation and Operation	32
Section Seven:	
System Commissioning and Operation	
Fill, Flush, and Check	35
Commissioning / Operation	36
Section Eight:	
System Troubleshooting	37
Section Nine:	
Oventrop Warranty	40

system components

The OVSOL System for solar energy described in this manual, when properly installed and maintained, meets the minimum standards established by the SRCC.

This certification does not imply endorsement or warranty of this product by the SRCC.

System Model	System Contents					
	OVF-32	Regusol EL 130	Tank Capacity and Type			
			Single Coil	Single Coil Electric	Dual Coil	Dual Coil Electric
OVSOL FP-2-SC	2	1	80 gallon	-	-	-
OVSOL FP-2-SCE	2	1	-	80 gallon	-	-
OVSOL FP-2-DC	2	1	-	-	80 gallon	-
OVSOL FP-2-DCE	2	1	-	-	-	80 gallon
OVSOL FP-3-SC	3	1	119 gallon	-	-	-
OVSOL FP-3-SCE	3	1	-	119 gallon	-	-
OVSOL FP-3-DC	3	1	-	-	119 gallon	-
OVSOL FP-3-DCE	3	1	-	-	-	119 gallon

OVF-32 - Oventrop 4' x 8' flat plate collector

introduction

OVSOL System

This manual provides installation instructions for OVSOL System for solar domestic hot water heating. The OVSOL solar energy system described in this manual, when properly installed and maintained, meets the minimum standards established by the SRCC.

This certification does not imply endorsement or warranty of this product by the SRCC.

Planning before the installation and use of the solar collector array should include:

- Solar hot water system design.
- Properly sized solar storage tank.
- Properly sized and insulated solar loop (plumbing circuit).
- An air bleed valve at the highest point in the collector circuit located for convenient access.
- Roof penetrations for piping to and from the collector.
- System components for closed loop solar systems—tank, heat exchanger, solar loop circulator, pressure relief valve, solar controller, expansion tank, fill and drain valves, pressure and temperature gauges.
- Propylene glycol (antifreeze) to provide protection from frost and high idle mode temperatures of 375 °F.

Requirements for each installation should be fully detailed by a system schematic and specifications.

The assembly and installation instructions described in this manual have been carefully prepared. It is very important to read these instructions thoroughly before proceeding with the collector installation. An effort has been made to conform procedures in this manual to the specifications of various governmental and agency solar programs. Also, many programs allow substitution of manufacturers' standards for program standards. If this is the case, the enclosed manual can be used to comply with program standards. Cases where it is unclear whether the enclosed manufacturers' standards can be substituted for program standards should be brought to the attention of the particular program administrator or to Oventrop Corporation for clarification.

Be certain to follow all applicable building and safety codes for installations of solar thermal collectors.

Compliance with local codes is essential. Local code requirements must be met for penetrating structural members and fire-rated assemblies. Collectors and piping must be installed in such a way that the performance of any structural member or fire-rated assembly is not reduced. Be especially aware of safety regulations when working upon rooftops. It is the buyer's responsibility to secure all permits and approvals before purchasing and attempting the installation of this equipment.

Specifications are subject to change without notice.

Installing Contractor

Company _____

Installer's name _____

Address _____

City, State, Zip _____

Phone Number _____

section one

Guidelines and Precautions

Installing Collector Arrays

It is not recommended to install more than six (6) flat plate collectors in a series. Larger installations will require parallel piping for balanced flow through each array. Balancing valves should be installed on multiple arrays. One roof mounting kit is needed for each single collector module.

Closed Loop and Drainback

OVSOL collectors can be installed for both closed loop and drainback solar heating applications.

Freeze Tolerance Limits

Freeze tolerance limits are based upon the freeze and burst protection of the antifreeze used in the solar closed loop, or the mixture of the glycol-to-water ratio. Oventrop NT-40 is a 40% glycol-to-water mix with freeze protection to -6° F and burst protection to -60° F. Oventrop NT-50 is a 50% glycol-to-water mix with freeze protection to -30° F and burst protection to -60° F. For additional protection, the Regusol 130 EL control has an antifreeze function ("OCF") that can be programmed to enable the circulator to protect the antifreeze from freezing or thickening.

Shedding Snow

If collectors are installed on a flat roof in an area that receives heavy snowfall, the lower end of the units should be at least 18" above the roof level to minimize chances of snow build-up on the bottom of the collectors.

Transport of Collector

The collector should be transported to the roof in parts and then assembled together on the rooftop.

Lightning Protection

In areas of high incidence of lightning, one lightning rod should be considered. If there is a ready-made lightning protection device, please connect it with the collector.

Precautions

Cover the solar collector when installing to prevent unwanted heating. Oventrop Corporation will not be liable for burns or personal injury due to the touching of a hot collector.

The maximum solar loop operating pressure is 87 psi. The pressure relief valve must be set to open below 87 psi. A 75 psi pressure relief valve is suggested. Normal operating pressures for a solar closed loop are 25 to 35 psi.

section two

Solar thermal system design guidelines

Solar hot water systems are simple in principal but complicated in practice. This guide is designed to describe and explain the process for designing a solar hot water system. There are many ways to design a solar hot water system to achieve the same end result. The two system types that Oventrop uses are external heat exchanger systems (i.e. the Regusol X) and Immersed coil heat exchangers (i.e. internal coil tanks). All of Oventrop's systems are based on one of these two variants.

Solar Design Basics

Incoming solar radiation at the earth's surface on a perfectly clear day is approximately 300 BTU/H per square foot. With that said, solar collector performance depends on several factors. These factors include, but are not limited to: ambient temperature at the location of the solar collector, required operating temperature of the working fluid in the collector, incoming solar radiation (energy), geographical location of the collector, shading of the collector, and inclination angle of the collector.

The difference in temperature between the working fluid and the ambient temperature drives the heat loss of the solar collector. This temperature difference has the greatest influence on the solar collector's thermal efficiency. This efficiency measures the solar collector's ability to convert incoming solar radiation to usable heat in the form of a hot working fluid. This hot working fluid can be used for any application.

The availability of solar radiation (energy) is dependent on weather, time of year, site shading, and collector inclination angle. Throughout the year, the distance of the sun from the horizon will change from the longest on the first day of summer to the shortest on the first day of winter. This translates to a 47-degree change in the sun's angle with respect to the collector throughout the year. The optimal inclination angle to minimize this change and maximize year-round performance is equivalent to the latitude at which the collector is located. Shading at the collector site determines the amount of available solar radiation to which the collector is exposed.

Understanding that all of the above factors affect the performance of the solar thermal collector, one cannot make a location independent generalization of collector performance.

Design conditions are calculated as the maximum instantaneous solar radiation, in other words, the most energy the system can handle at any given time. For design conditions we assume the collector is at an operating efficiency of 75%, on a clear day, facing south, with no shading. Due to this efficiency the maximum output of the solar collector at design is rated at 225 BTU/H per square foot. This value is in no way a guarantee or estimate of any Oventrop collector's performance. The table below shows the design BTU/H rating of each Oventrop solar collector.

Collector Type	Design Conditions BTU/H rating
OV 5-16 Evacuated tube collector	6,277 BTU/H
OVF-21 Flat plate collector	4,230 BTU/H
OVF-32 Flat plate collector	6,615 BTU/H
OVF-40 Flat plate collector	8,280 BTU/H

Table 2, below, shows the design flow rates for each Oventrop collector type.

Collector Type	Design Flow Rate per collector
OV 5-16 Evacuated tube collector	0.75 GPM
OVF-21 Flat plate collector	0.525 GPM
OVF-32 Flat plate collector	0.80 GPM
OVF-40 Flat plate collector	1.0 GPM

These flow rates were chosen based on the collection area of each solar collector and the incoming solar radiation at design conditions. The flow rates allow the collectors to achieve an 18 degree Fahrenheit temperature rise across the solar loop.

‘The sun is the source, the system is the battery.’

Solar energy is only available for a limited time during each day. It is because of this that the energy must be captured and stored for later use. The amount of energy stored is related to the system operating temperature (i.e. radiant floor heat at 100F or fan coil units at 180F), the storage volume, and to the maximum temperature in the storage vessel. Maximum energy storage [BTU’s] is calculated using equation 1, below.

$$\text{Maximum Stored Energy} = 8.33 \times \text{Storage volume [Gal]} \times (\text{Max. tank temp.} - \text{System operating temp.})$$

Where, Storage volume is in gallons and all temperatures are in Fahrenheit. Optimization of this equation has determined the design number of gallons per collector. The table below shows the number of gallons of storage recommended per collector.

Collector Type	Gallons of Storage per Collector
OV 5-16 Evacuated tube collector	66 Gallons
OVF-21 Flat plate collector	27 Gallons
OVF-32 Flat plate collector	41 Gallons
OVF-40 Flat plate collector	53 Gallons

These storage values are calculated for a national average. Since daily solar radiation varies significantly from the South to the North, these storage values are not required, only recommended. Less storage can be used in the northern latitudes and more storage can be used in the southern latitudes. The storage values should only vary plus or minus 5% from the recommended values listed above.

Another way to think of solar storage is as the fuel tank of the system. It is used to store energy that can be used over the entire day. In this way the daily load is matched to the daily collector output. Oventrop solar hot water systems are designed to optimize the transfer of energy from the collectors to the solar storage vessel.

Small systems

Internal coil tanks are used for Oventrop smaller systems. This allows for the ease of installation for system packages. Oventrop has pre-packaged solar domestic hot water systems for daily loads of 80 and 115 gallons. Depending on location these packaged systems will provide between 30 and 70 percent of the annual domestic hot water load.

Using a similar configuration as the pre-packaged systems, larger domestic hot water loads can be accommodated. Variations of small systems are sized by tank size and can be arranged for up to 160 gallons and 230 gallons of daily usage. These small systems are comfortably in the design range of the Regusol EL 130 solar pumping station. This pumping station is designed for a maximum flow rate of four (4) gallons per minute. Because the Regusol EL 130 is constructed in 3/4", the maximum flow rate is based on the maximum trouble free flow through 3/4" pipe.

Medium systems

Medium systems are above the flow range established for the Regusol EL 130 and have increasingly larger storage requirements. It is for these reasons that the Regusol-X pumping station with heat exchanger was developed. External heat exchangers provide flexibility of design and reduce cost when considering larger storage volume and collector arrays. The Regusol-X is designed to be used with any storage vessel that is built for hot water storage; it does not require internal heat exchangers.

The design limits for the Regusol-X are based on the pressure drop through the heat exchanger, the pump capacity, and the maximum output of the heat exchanger. The table below lists the maximum number of collectors allowed to be used with each Regusol-X.

For Single Speed Pumps

Collector Type	Maximum number of collectors on one Regusol EL130*	Maximum number of collectors on one Regusol-X 15**	Maximum number of collectors on one Regusol-X 25**
OV 5-16 Evacuated tube collector	3	6	8
OVF-21 Flat plate collector	7	9	12
OVF-32 Flat plate collector	5	6	8
OVF-40 Flat plate collector	4	5	6

Using an external heat exchanger allows for either multiple or single tank configurations. As long as the storage is sized correctly the tanks can be in any configuration.

For Three Speed Pumps

Collector Type	Maximum number of collectors on one Regusol EL130*	Maximum number of collectors on one Regusol-X 15**	Maximum number of collectors on one Regusol-X 25**
OV 5-16 Evacuated tube collector	4	7	8
OVF-21 Flat plate collector	7	10	12
OVF-32 Flat plate collector	5	6	8
OVF-40 Flat plate collector	4	5	6

* No more than three (3) OV 5-16 tube collectors are to be piped in series through the Regusol EL130 without a booster pump.

** No more than two (2) OV 5-16 tube collectors are to be piped in series through the Regusol X without a booster pump.

Oventrop Solar Systems Sizing Chart

The following solar sizing charts shows various combinations of solar collector quantities to Regusol pumping stations and the design solar storage volume.

Tank selections are up to the designer for Regusol X systems and larger.

For Single Speed Pumps

Collector Type	OVF-21 Flat plate collector		OVF-32 Flat plate collector		OVF-40 Flat plate collector	
	Pumping Station	Storage in Gallons	Pumping Station	Storage in Gallons	Pumping Station	Storage in Gallons
2	Regusol EL130	54	OVSOL FP-2 package		Regusol EL130	106
3	Regusol EL130	81	OVSOL FP-3 package		Regusol EL130	159
4	Regusol EL130	108	Regusol EL130	160	Regusol EL130	212
5	Regusol EL130	135	Regusol EL130	205	Regusol X-15	265
6	Regusol EL130	162	Regusol X-15	246	Regusol X-25	318
7	Regusol EL130	189	Regusol X-25	287		
8	Regusol EL130	216	Regusol X-25	328		
9	Regusol X-15	243				
10	Regusol X-25	270				
11	Regusol X-25	297				
12	Regusol X-25	324				

For Three Speed Pumps

Collector Type	OVF-21 Flat plate collector		OVF-32 Flat plate collector		OVF-40 Flat plate collector	
	Pumping Station	Storage in Gallons	Pumping Station	Storage in Gallons	Pumping Station	Storage in Gallons
2	Regusol EL130	54	OVSOL FP-2 package		Regusol EL130	106
3	Regusol EL130	81	OVSOL FP-3 package		Regusol EL130	159
4	Regusol EL130	108	Regusol EL130	160	Regusol EL130	212
5	Regusol EL130	135	Regusol EL130	205	Regusol X-15	265
6	Regusol EL130	162	Regusol X-15	246	Regusol X-25	318
7	Regusol EL130	189	Regusol X-25	287		
8	Regusol X-15	216	Regusol X-25	328		
9	Regusol X-15	243				
10	Regusol X-15	270				
11	Regusol X-25	297				
12	Regusol X-25	324				

section three

Collector Layout, Orientation, and Siting

Place the collector where it will receive the maximum amount of sunlight available in your location. OVSOL collectors may be installed on a roof, against a south facing wall, or on the ground.

Orientation

Orientation and tilt are critical to performance. The OVSOL collectors should be oriented (faced) as close to true south as practical, although they may be faced as much as 20° east or west of true south with less than 5% loss in capacity. Because the earth's magnetic field is not aligned parallel to the earth's north-south axis, there are some parts of the United States where the needle of a magnetic compass can point as much as 20° east or west of true north. There are several ways to determine true south in your area. You

can consult a local surveyor, a plot map in your local tax office, or a recent isogonic chart of the United States published by the U.S. Coast and Geodetic Survey. Adjust your magnetic compass reading according to the meridian nearest to you. Do not use old charts, as there are annual variations in the readings. When using a magnetic compass, beware of standing near large metallic objects or power lines because they will affect the compass readings.

Shading

Trees, chimneys, dormers, other buildings, new construction, and even fences may shade the collector array, especially in the winter when sun angles are low and shadows are long. Be sure the collectors are placed where they will be not shaded by these obstructions. As a rule, no more than 5% of the collector area should be shaded between the hours of 9:00 a.m. and 3:00 p.m. It is highly advised to make use of a solar site selector while determining suitability for a collector site.

Angle of Inclination or Tilt Angle

For domestic water, use an optimum tilt of the site's latitude plus 5°, although the slope may be 10° greater or less with a capacity loss of under 5% for the system. For a solar space heating system, a steeper tilt angle is important for optimal winter performance. The steeper tilt will favor winter system operations when the sun is low in the sky. Therefore, for space heating systems chose a tilt of latitude plus 15°.

The variation of 10° either way will not seriously affect the total annual performance of the system, all other things being equal.

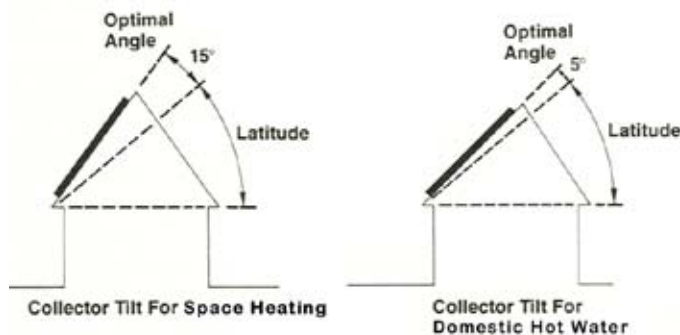

The following chart will help you determine the tilt angle of roof pitches. For space heating systems, always

have collectors sloped at optimal tilt for winter performance. Install a collector rack for tilt angle support whenever necessary.

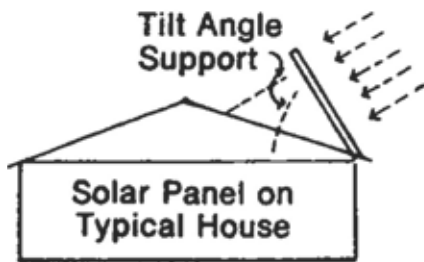

Roof Pitch	Tilt Angle	Roof Pitch	Tilt Angle
4/12	18°	12/12	45°
6/12	26°	14/12	49°
10/12	39°	22/12	61°

Integrating with Building Architecture

Maintaining a pleasing appearance to the building's architecture is important for adding solar collectors to a roof or on the ground. Most homes are not oriented well for solar gain, so getting the collectors at just the right orientation and tilt may not integrate well with the roof lines.

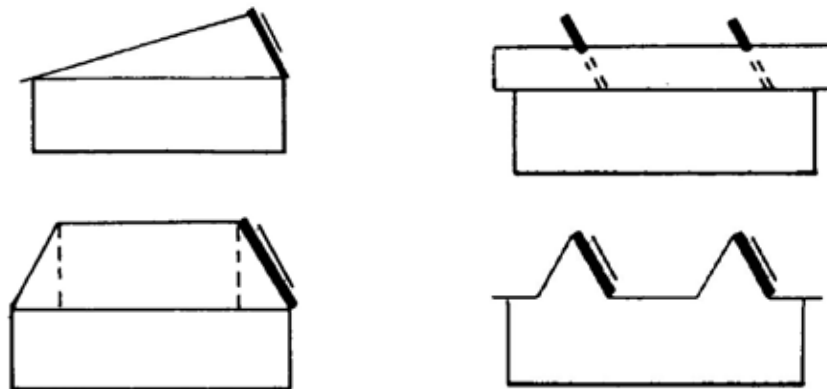

With domestic hot water systems, there may be greater variations to tilt and orientation without large annual losses, and in some cases may justify flush-mounting collectors. Space heating systems must have a steep slope and be oriented within 30° of true south. For these larger space heating systems, the layout should integrate into the roofline. For new construction, integrating OVSOL collectors into the building's roof system should be addressed by the solar designer to the architect.

Shading

To avoid shading by collectors on each other, the front to front dimension must be 2.5 times the highest point of the front collector.

Section Four

Oventrop Flat Plate solar thermal collector

(3'x7' model OVF-21 - **540 03 07**, 4'x8' model OVF-32 - **540 04 08**, 4'x10' model - OVF-40 - **540 04 10**)

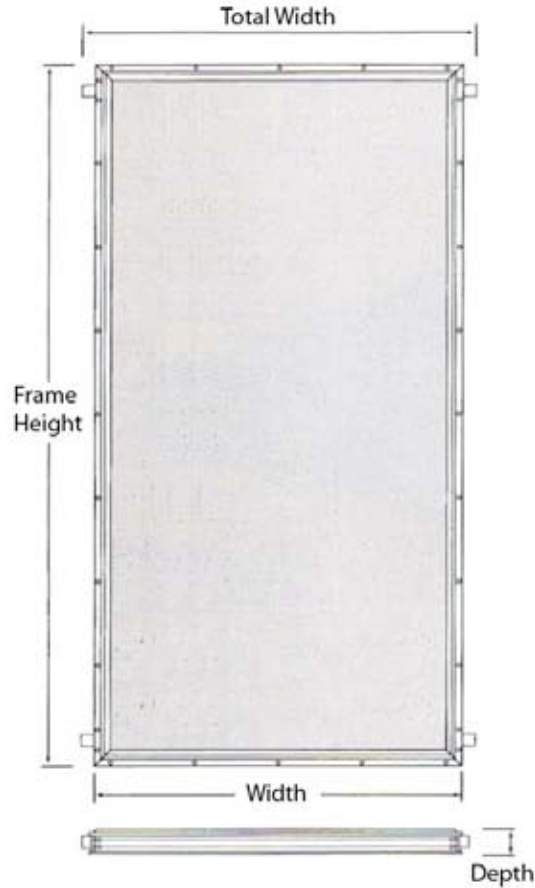

Model (Part Number)	3' x 7' (540 03 07)	4' x 8' (540 04 08)	4' x 10' (540 04 10)
Gross Collector Area	21.5 sqft	32.7 sqft	40.7 sqft
Frame Height	86 inches	98 inches	122 inches
Frame Width	36 inches	48 inches	48 inches
Frame Depth	3-1/8 inches	3-1/8 inches	3-1/8 inches
Total Width	38 inches	50 inches	50 inches
Weight	76 lbs.	116 lbs.	151 lbs.

Adjustable Rack Mounting Kit for flat plate collectors

540 00 28-FP

- for all flat plate collectors (OVF-21, OVF-32, OVF-40)

Contents:

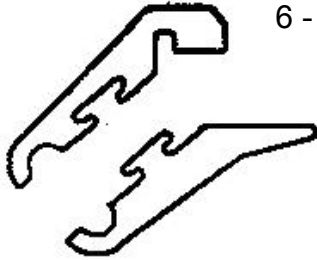

6 - Flat Plate Quick-Lock collector clamp

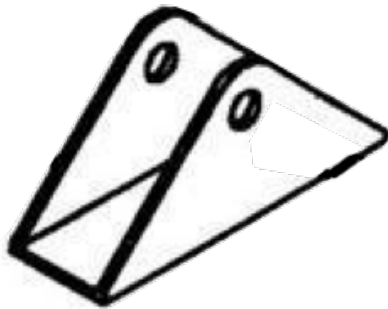

4 - Triangle base bracket (foot)



4 - 2 inch bolt/washer/nut set



2 - 4 inch bolt/washer/nut set



2 - Aluminum square tube
Dimensions: 72L x 1.0W x 1.0H inches

Measuring and cutting the rack legs

Table 1 below is to help you find distances between the front and rear feet (B), and the cut length for the rack leg (A) at various collector tilt angles.

The table is for collector tilt angle from a horizontal plane, such as for a flat roof or for ground mounting. (figure 1)

When mounting on a pitched roof (figure 2) the table can be used by subtracting the roof pitch (angle) from the collector tilt angle to find the remaining angle for Table 1. With this method the collector legs will be perpendicular with the roof pitch (figure 2).

Table 1

Collector Tilt Angle in degrees from horizontal	A / B for OVF - 21 in inches	A / B for OVF - 32 in inches	A / B for OVF - 40 in inches
5	8 / 86	9 / 98	11 / 122
10	15 / 85	17 / 97	21 / 120
15	22 / 83	25 / 95	32 / 118
20	30 / 81	34 / 92	42 / 115
25	36 / 78	42 / 89	52 / 111
30	43 / 74	49 / 85	61 / 105
35	49 / 71	56 / 80	70 / 100
40	55 / 66	63 / 75	
45	61 / 61	69 / 69	
50	66 / 55		
55	71 / 49		

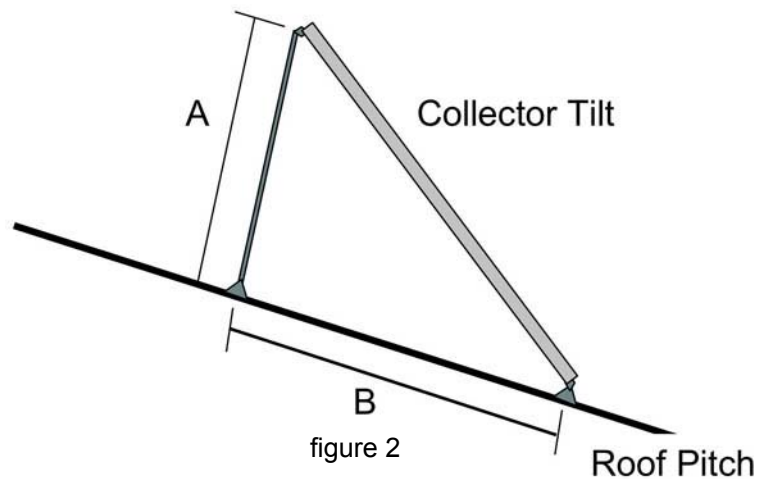
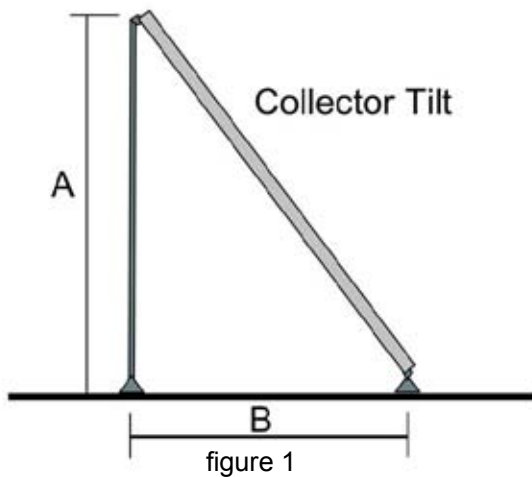

Front and rear hinge diagram 1

Mounting Hardware and Installation

The adjustable rack installation hardware is specially designed to speed collector installation. This hardware consists of four Quick-Lock collector clamps for the rear top hinge, two Quick-Lock collector clamps with locking screws for the front bottom hinge, four triangle brackets (collector feet), two aluminum square tube strut for collector legs, bolts, nuts and washers.

Install the triangle brackets.

The rear struts should be cut and drilled to the desired length from Table 1.

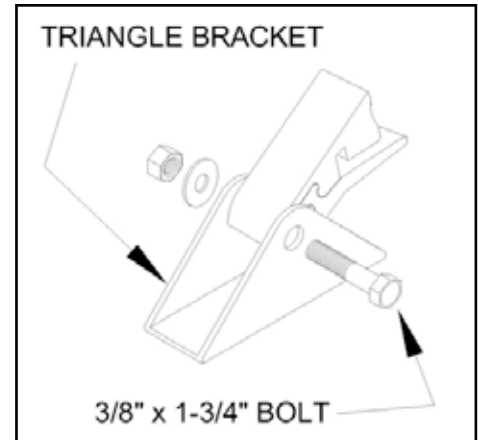

front hinge Diagram 1

Attach two Quick-Lock collector clamps with locking screws to bottom of the collector. Keep the locking screws loose. Secure the bottom Quick-Lock clamps on the collector and drop the clamp into the triangle bracket using the bolt, washer, and nut provided. Tighten locking screws after collector is set on the triangle brackets. See diagram 1.

Attach the four Quick-Lock collector clamps to the top of the collector. Using two Quick-Lock clamps per collector leg, bolt the collector leg (mounting strut) to the top of the collector. Attach both collector legs.

Raise the collector and bolt the bottom of the collector legs to the collector foot with the bolt, washer, and nut provided. See diagram 2.

Square up the collector legs and tighten all the nuts and bolts at the collector feet and the rear collector hinge.

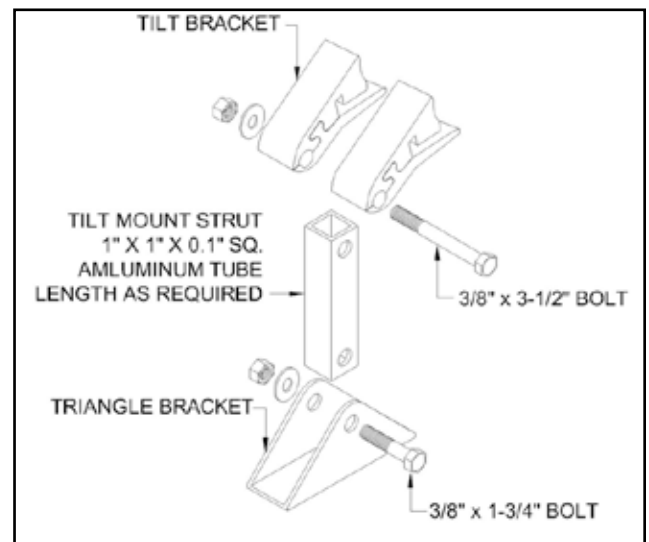

Rear hinge and strut Diagram 2

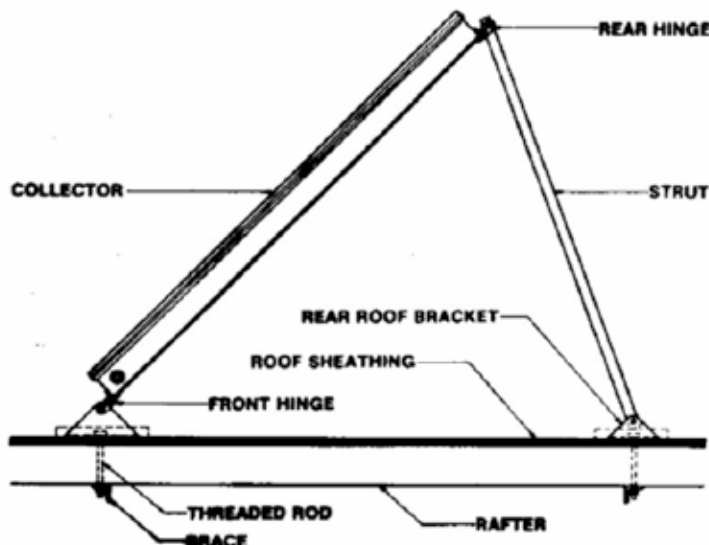

Flush Mounting Kit for flat plate collectors

540 00 28-FPFM

- for all flat plate collectors (OVF-21, OVF-32, OVF-40)

Contents:

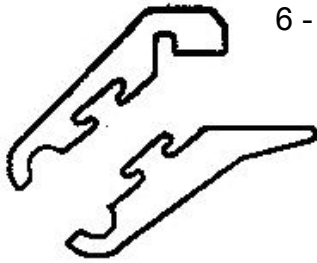

6 - Flat Plate Quick-Lock collector clamp



4 - 2 inch bolt/washer/nut set

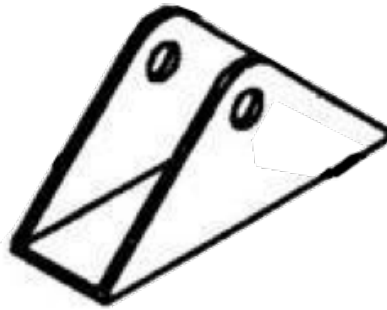

4 - Triangle base bracket (foot)

OVF - Series flat plate collectors			Center Line to Center Line distance from top to bottom foot [in]
Model	Size [ft]	Outside Box Dimensions (WxL) [in]	
OVF-21	3 x 7	35.875 x 86.125	88.25
OVF-32	4 x 8	47.875 x 98.125	100.25
OVF-40	4 x 10	47.875 x 122.125	124.25

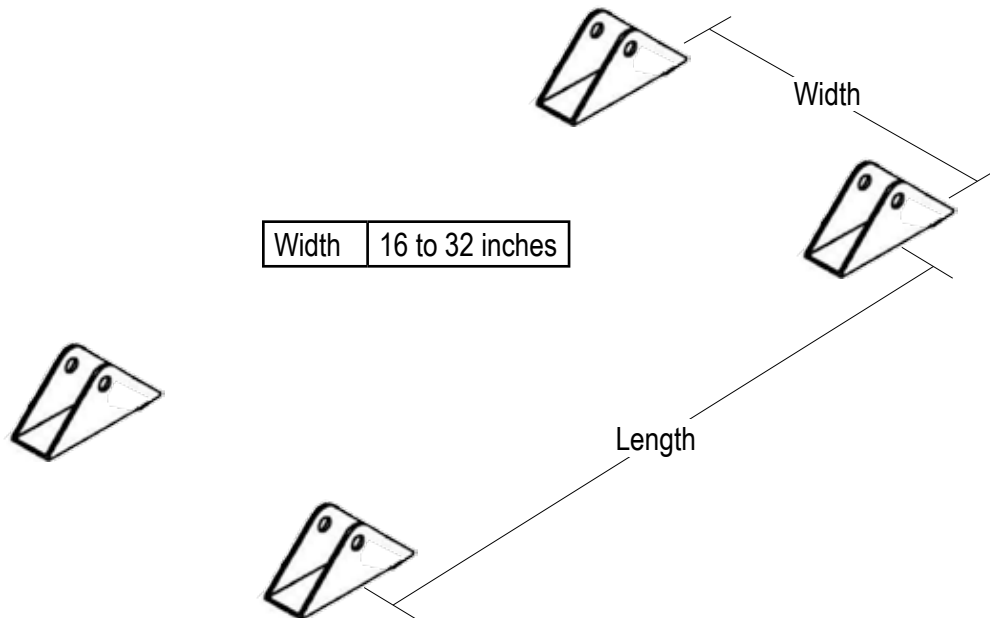

Strut Mount Clips for flat plate collectors

540 00 28-FC

- for all flat plate collectors (OVF-21, OVF-32, OVF-40)



Set of 4 clips

Collector clips are designed to make Oventrop flat plate collectors versatile enough to mount on strut channel assemblies, especially those with locking strut nuts or locknuts.

Required but not provided are strut channel, strut locknuts, bolts and washers.

Usually the Collectors are attached and secured to two horizontal load bearing strut channels placed 1 - 2 ft. in from the collector ends.

See figure below.

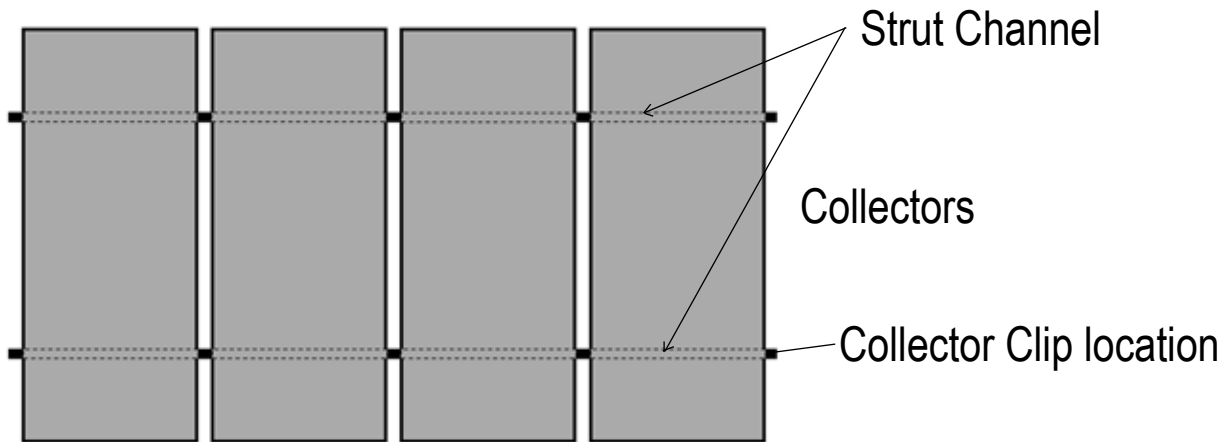

To connect the clips to the strut channel raise the collector onto the installed horizontal strut.

Attach the collector to the strut by using a collector clip, a bolt and a strut locknut. Each collector has four mounting clips.

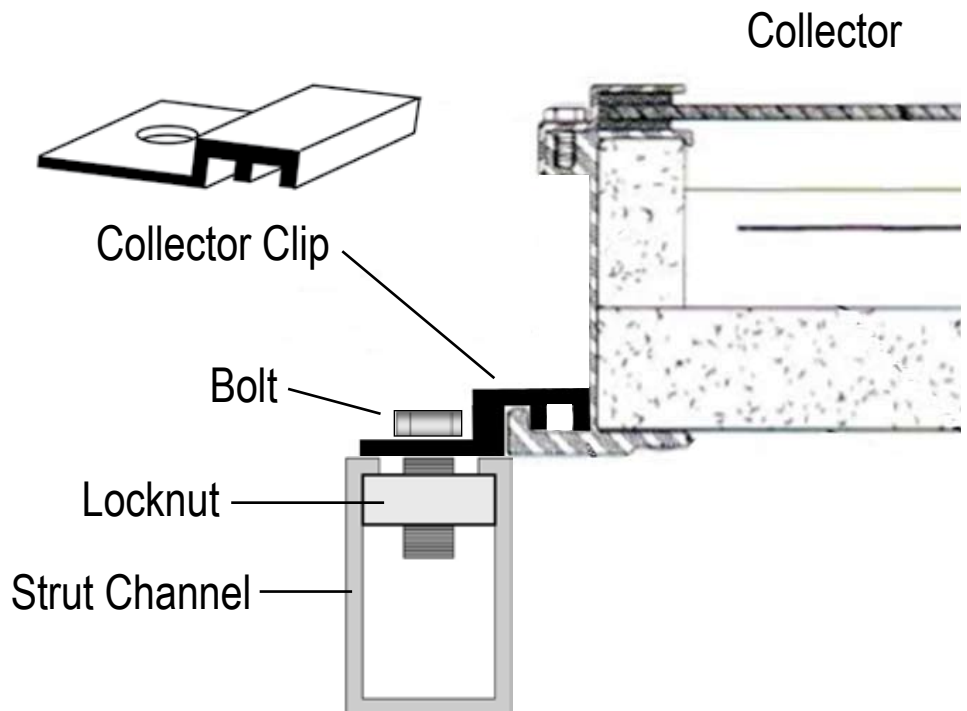

Mounting the Collector Feet

There are two acceptable ways to secure the collector mounting brackets to the roof.

1. Lag Bolt Mounting
2. Spanner Mounting

1. Lag Bolt Mounting

In lag bolt mounting, after the brackets are positioned, drill holes into the rafters for the lag bolts. Caulk is applied between the bracket and the roof. Tighten down until the bracket is tightly secured to the roof. Be careful not to over-tighten and bell out the roof underneath the bracket. It is very important that the penetrations through the roof be well sealed. It should be carefully checked that all bolts are coated with tar and that no leaks are possible.

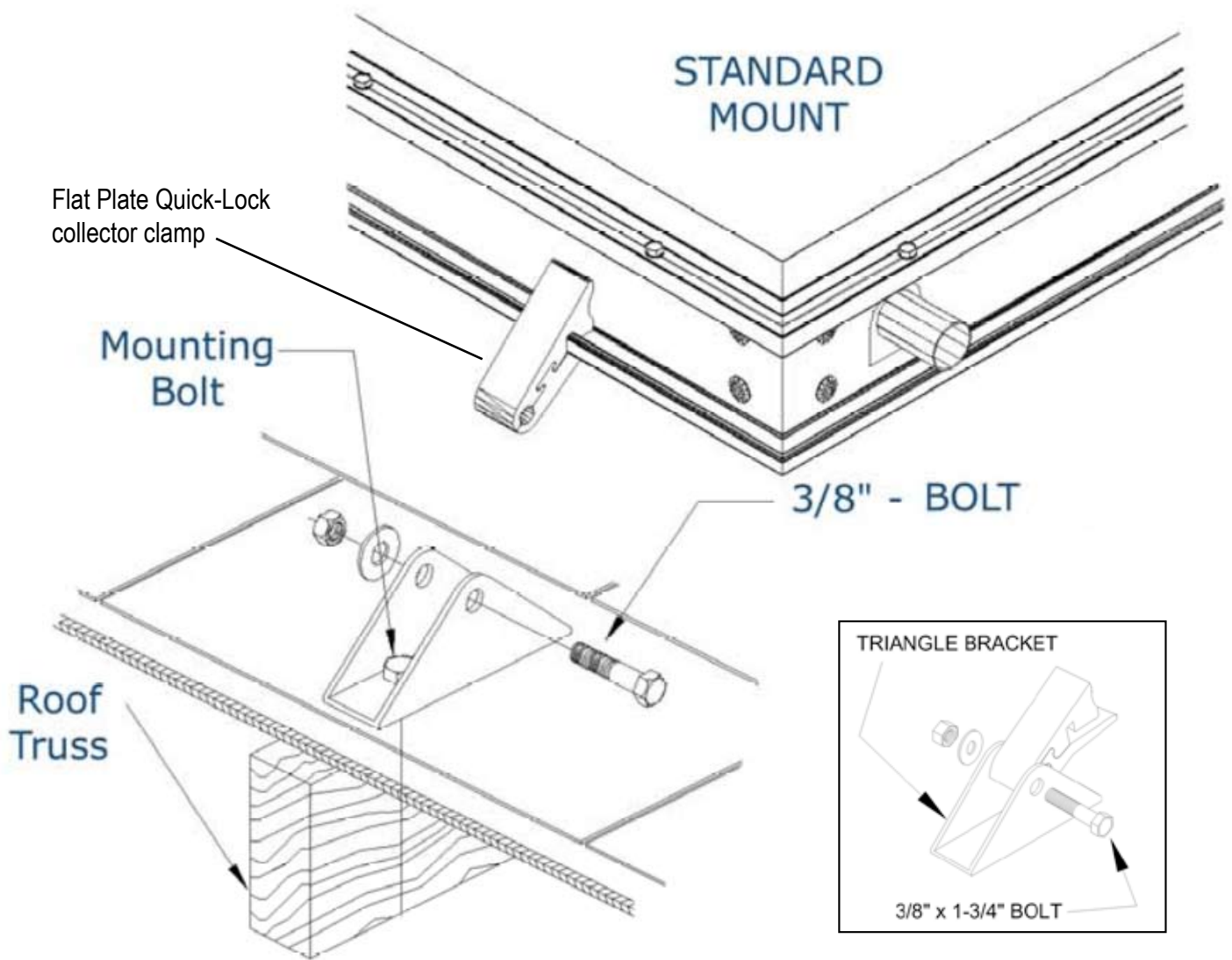

2. Spanner Mounting

In spanner mounting, after the brackets are positioned on the chalk line, a 3/8" hole is drilled between the rafters. Aluminum flashing is positioned over the hole where the top of the flashing is extended up under the shingle above the 3/8" hole and extends down over it. Caulk is applied between the flashing and the roof. The bracket is then positioned over the 3/8" hole using sealant between the bracket and the flashing. A piece of 3/8" all-thread is then inserted through the hole. A washer and nut secures the all-thread to the bracket (be sure the seal underneath the washer and on top of the nut). The all-thread rod should extend about 4" below the roof rafters. Drill a 3/8" hole in a 2 x 4 and insert the all-thread rod through it. The 2 x 4 should span 2 rafters. With a washer and double bolt secure the all-thread to the 2 x 4. Tighten down until the bracket is tightly secured to the roof. Be careful not to over-tighten and bell out the roof underneath the bracket (See Figure to right). It is very important that the penetrations through the roof be well sealed. It should be carefully checked that all bolts are coated with tar and that no leaks are possible.

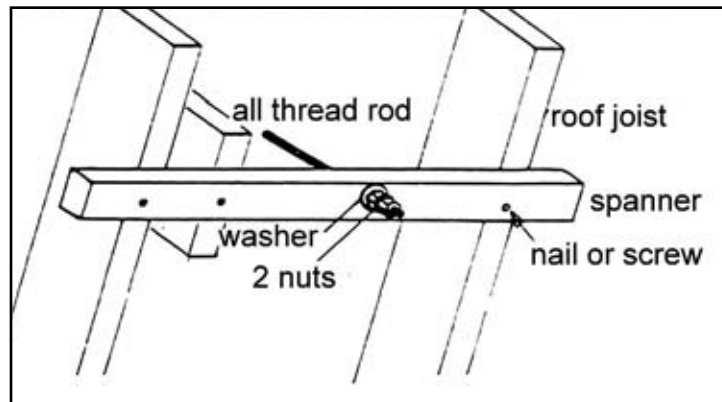

Section Four

Flat Plate Collector Piping

The piping of the system should be made of hard tubing such as stainless steel line sets, or copper tubing, type "M" or "L". Up to 4 collectors use 3/4" copper tubing, 5 - 8 collectors use 1" copper tubing. Insulate all copper tubing with high temperature elastomeric foam (3/4" wall exterior, 1/2" inch wall interior) and painted for UV protection. Insulation may also be done with 3/4" rigid foam and wrapped with UV resistant jacket.

Care should be taken in the spacing of collectors for soldering copper couplings or copper unions into place. Mount the collectors to align the manifolds. A manual air vent must be installed at the top of the collector at the highest point. Soldered connections should be made with 95/5 or better.

The manifolds of the collector are in 1" copper pipe size (Figure 13). Collectors can be sweat soldered together with 1" copper couplings or with copper unions. Careful attention must be made for these connections. Copper couplings may go out of round when using channel lock wrenches to turn them into place, so apply light pressure to the tool when installing coupling between collectors. Teflon tape or high temperature pipe sealant should be used when making threaded connections to the manual air vent and other threaded connections.

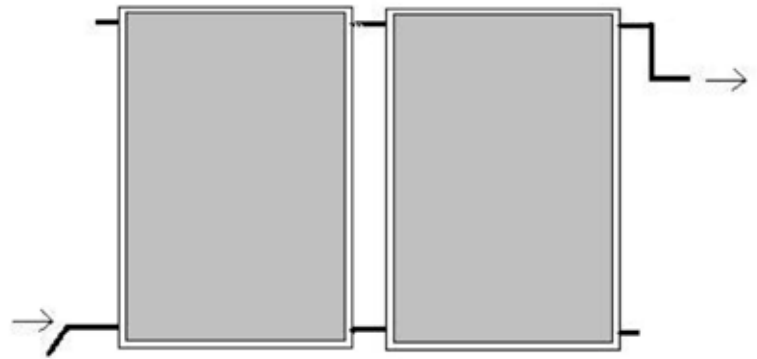
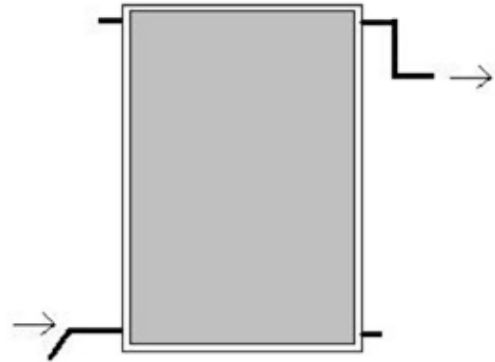

Sensor Mounting at Collector

The collector sensor is attached to the copper tubing with a hose clamp, located at the high point at the collector. The sensor is measuring the hottest collector temperatures in the collector loop and must be measuring outgoing temperatures from the collector. The collector sensor must be strapped on the copper tubing immediately following the collector, be well insulated and weatherproof.



OVSOL System FP-2-SCE / 80 gallon, Flat plate, Single coil electric tank

System Assembly

Installing OVSOL System FP-2-SCE

Model Number 540 04 08K-SCE

Solar Closed-Loop Domestic Hot Water System

Oventrop Components

Two OVF-32 Flat Plate Solar Collectors	filled weight: 550 lbs.
Regusol 130 EL Solar Transmission Station	filled weight: 20 lbs.
80 Gallon OVSOL glass lined Tank	filled weight: 920 lbs.
Regusol Fill and Flush Valve	
Oventrop NT Propylene Glycol Antifreeze	

System Design Description

The solar closed-loop heating system consists of the Oventrop Regusol 130 EL pump and control station, one OV-5 evacuated tube collector, and an 80 gallon glass lined tank with one internal coil and an electric backup element. An expansion tank is installed at the Regusol on the safety group. Oventrop NT propylene glycol antifreeze is filled into the closed loop system through the Regusol fill and flush valve.

Cold water is piped to the solar tank. An anti-scald valve must be installed for hot water mixing to hot water fixtures if the solar tank high limit in the Regusol controller is set above 120 °F.

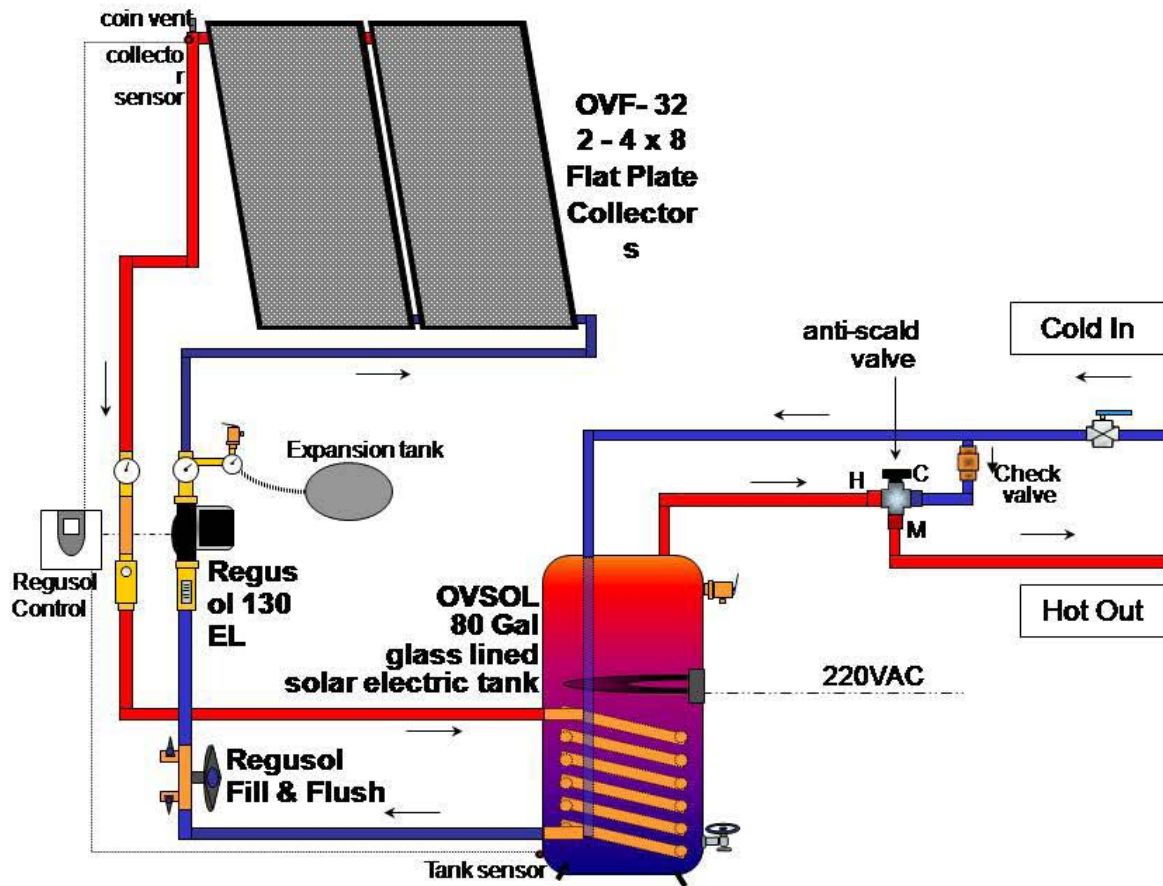

OVSOL System FP-2-DC / 80 gallon, Flat plate, Dual coil tank

System Assembly

Installing OVSOL System FP-2-DC
 Model Number 540 04 08K-DC
 Solar Closed-Loop Domestic Hot Water System

Oventrop Components

Two OVF-32 Flat Plate Solar Collectors	filled weight: 550 lbs.
Regusol 130 EL Solar Transmission Station	filled weight: 20 lbs.
80 Gallon OVSOL glass lined Tank.	filled weight: 970 lbs.
Regusol Fill and Flush Valve	
Oventrop NT Propylene Glycol Antifreeze	

System Design Description

The solar closed-loop heating system consists of the Oventrop Regusol 130 EL pump and control station, one OV-5 evacuated tube collector, and an 80 gallon glass lined tank with two internal coils. An expansion tank is installed at the Regusol on the safety group. Oventrop NT propylene glycol antifreeze is filled into the closed loop system through the Regusol fill and flush valve.

Cold water is piped to the solar tank. An anti-scald valve must be installed for hot water mixing to hot water fixtures if the solar tank high limit in the Regusol controller is set above 120 °F. The top coil is piped to the boiler in the manner of a standard indirect water heater.

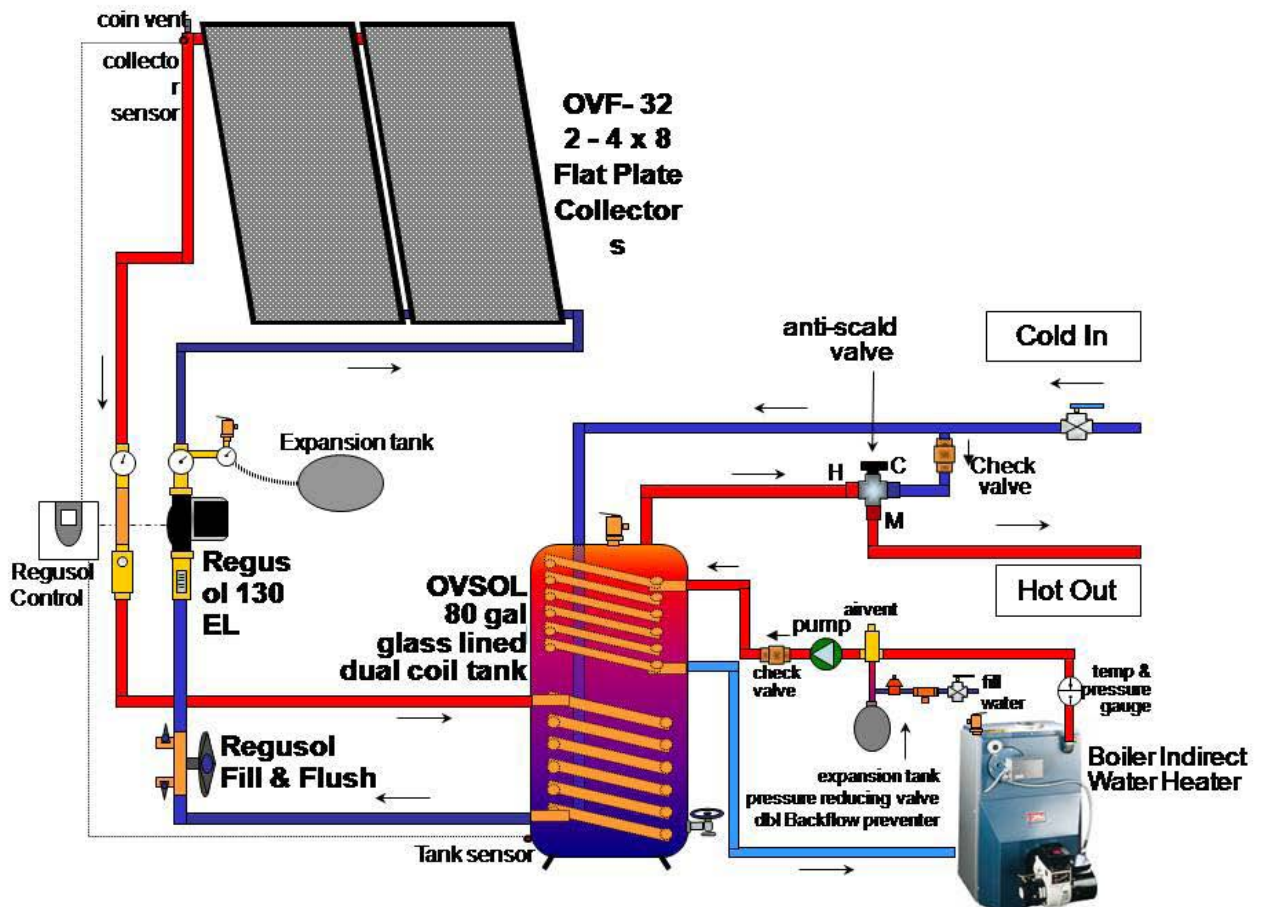

OVSOL System FP-2-DCE / 80 gallon, Flat plate, Dual coil electric tank

System Assembly

Installing OVSOL System FP-2-DCE
 Model Number 540 04 08K-DCE
 Solar Closed-Loop Domestic Hot Water System

Oventrop Components

Two OVF-32 Flat Plate Solar Collectors	filled weight: 550 lbs.
Regusol 130 EL Solar Transmission Station	filled weight: 20 lbs.
80 Gallon OVSOL glass lined Tank.	filled weight: 970 lbs.
Regusol Fill and Flush Valve	
Oventrop NT Propelyne Glycol Antifreeze	

System Design Description

The solar closed-loop heating system consists of the Oventrop Regusol 130 EL pump and control station, one OV-5 evacuated tube collector, and an 80 gallon glass lined tank with two internal coils and an electric backup element. An expansion tank is installed at the Regusol on the safety group. Oventrop NT propelyne glycol antifreeze is filled into the closed loop system through the Regusol fill and flush valve.

Cold water is piped to the solar tank. An anti-scald valve must be installed for hot water mixing to hot water fixtures if the solar tank high limit in the Regusol controller is set above 120 °F. The top coil is piped to the boiler in the manner of a standard indirect water heater.

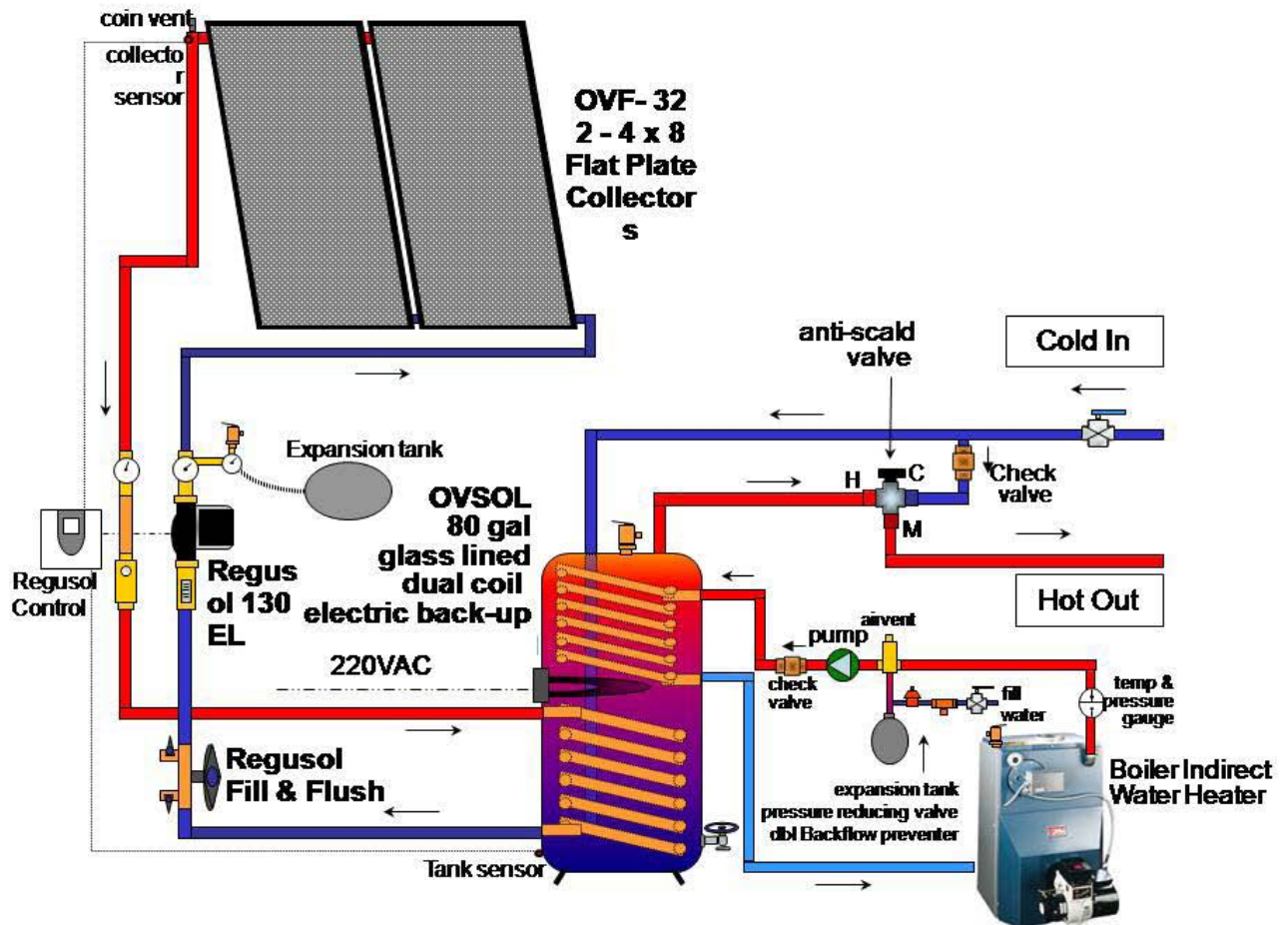

OVSOL System FP-3-SC / 119 gallon, Flat plate, Single coil tank

System Assembly

Installing OVSOL System FP-3-SC
 Model Number 540 34 08K-SC
 Solar Closed-Loop Domestic Hot Water System

Overtrop Components

Three OVF-32 Flat Plate Solar Collectors	filled weight: 675 lbs.
Regusol 130 EL Solar Transmission Station	filled weight: 20 lbs.
119 Gallon OVSOL glass lined Tank	filled weight: 1315 lbs.
Regusol Fill and Flush Valve	
Overtrop NT Propylene Glycol Antifreeze	

System Design Description

The solar closed-loop heating system consists of the Overtrop Regusol 130 EL pump and control station, one OV-5 evacuated tube collector, and an 119 gallon stainless steel tank with one internal coil. An expansion tank is installed at the Regusol on the safety group. Overtrop NT propylene glycol antifreeze is filled into the closed loop system through the Regusol fill and flush valve.

Cold water is piped to the solar tank and in series with the back-up hot water heater. Solar bypass valves are installed for servicing the solar tank. Back-up hot water heater bypass valves may be installed to bypass the hot water heater. An anti-scald valve must be installed for hot water mixing to hot water fixtures if the solar tank high limit in the Regusol controller is set above 120 °F.

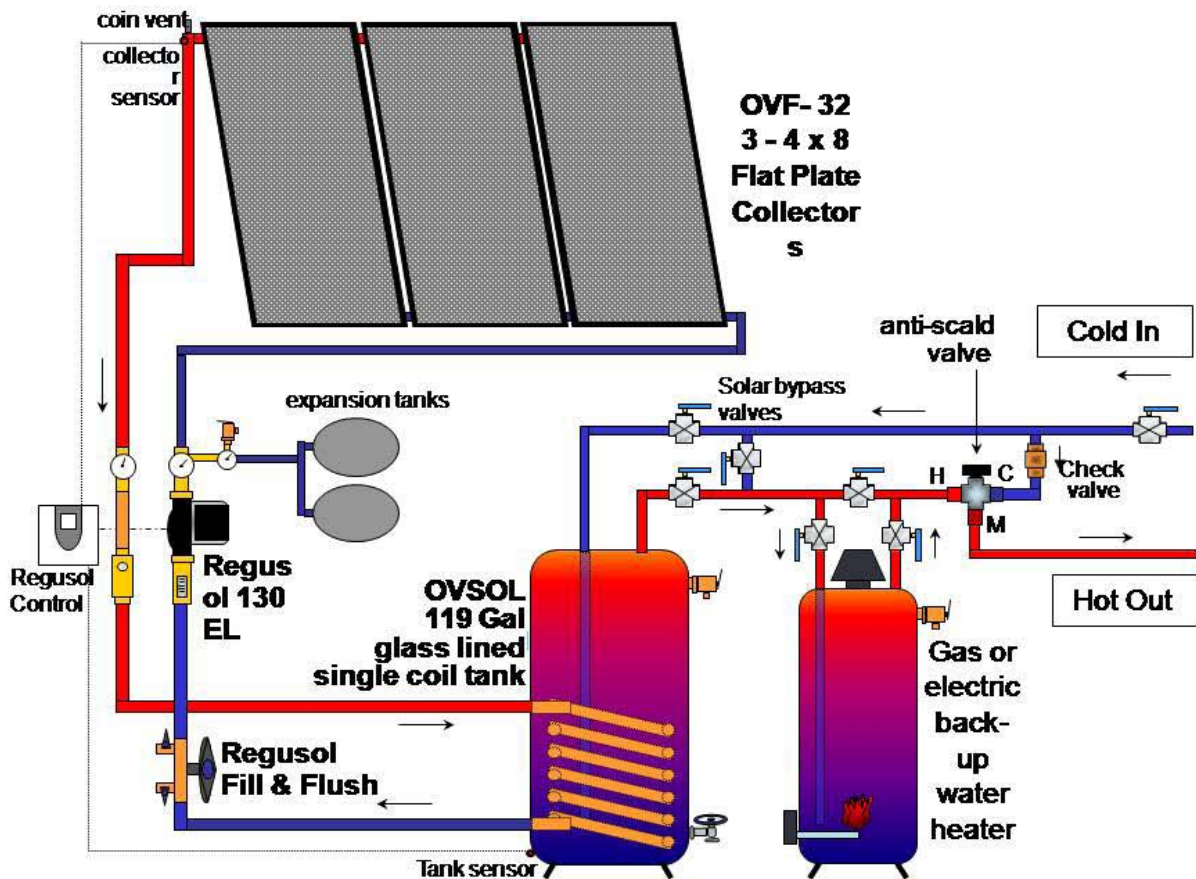

OVSOL System FP-3-SCE / 119 gallon, Flat plate, Single coil electric tank

System Assembly

Installing OVSOL System FP-3-SCE
Model Number 540 34 08K-SCE
Solar Closed-Loop Domestic Hot Water System

Oventrop Components

Three OVF-32 Flat Plate Solar Collectors	filled weight: 675 lbs.
Regusol 130 EL Solar Transmission Station	filled weight: 20 lbs.
119 Gallon OVSOL glass lined Tank	filled weight: 1315 lbs.
Regusol Fill and Flush Valve	
Oventrop NT Propylene Glycol Antifreeze	

System Design Description

The solar closed-loop heating system consists of the Oventrop Regusol 130 EL pump and control station, one OV-5 evacuated tube collector, and an 119 gallon stainless steel tank with one internal coil and an electric element. An expansion tank is installed at the Regusol on the safety group. Oventrop NT propylene glycol antifreeze is filled into the closed loop system through the Regusol fill and flush valve.

Cold water is piped to the solar tank. An anti-scald valve must be installed for hot water mixing to hot water fixtures if the solar tank high limit in the Regusol controller is set above 120 °F.

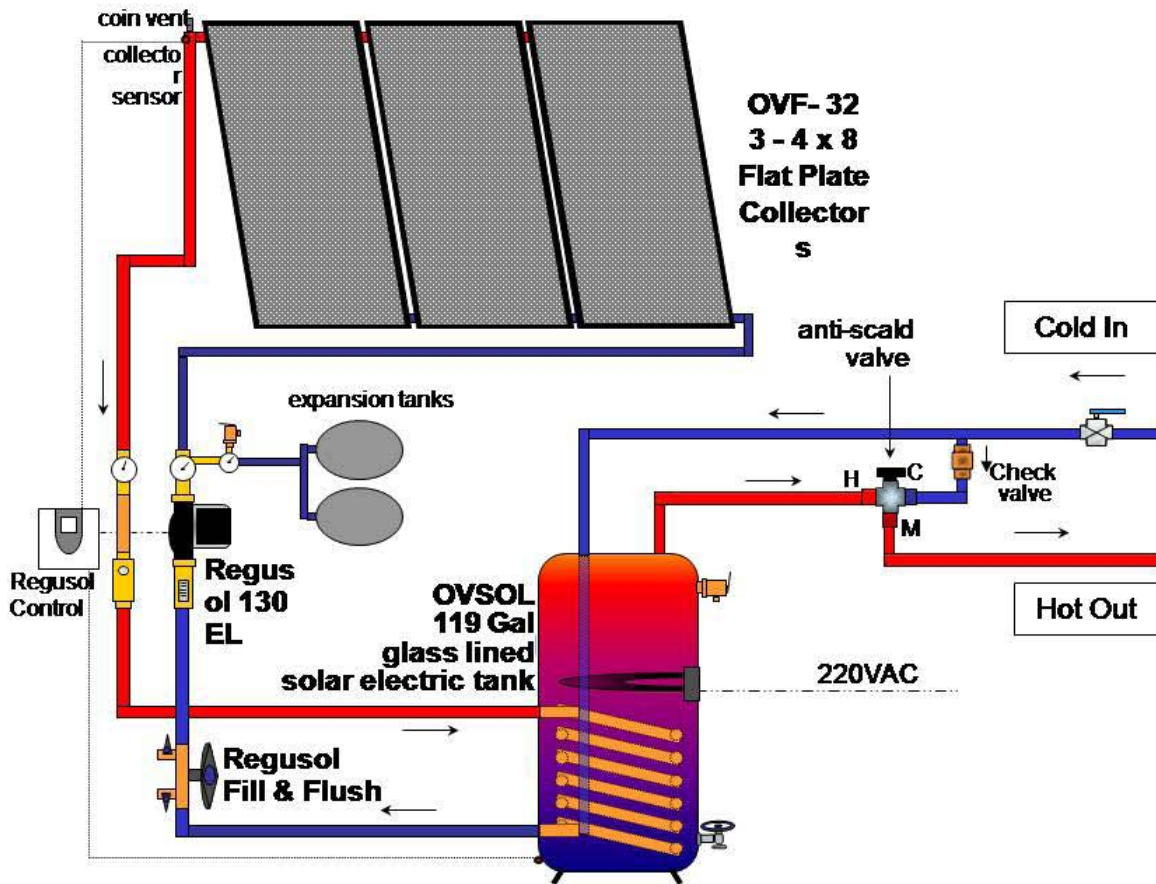

OVSOL System FP-3-DC / 119 gallon, Flat plate, Dual coil tank

System Assembly

Installing OVSOL System FP-3-DC
 Model Number 540 34 08K-DC
 Solar Closed-Loop Domestic Hot Water System

Oventrop Components

Three OVF-32 Flat Plate Solar Collectors	filled weight: 675 lbs.
Regusol 130 EL Solar Transmission Station	filled weight: 20 lbs.
119 Gallon OVSOL glass lined Tank	filled weight: 1340 lbs.
Regusol Fill and Flush Valve	
Oventrop NT Propelyne Glycol Antifreeze	

System Design Description

The solar closed-loop heating system consists of the Oventrop Regusol 130 EL pump and control station, one OV-5 evacuated tube collector, and an 119 gallon glass lined tank with two internal coils. An expansion tank is installed at the Regusol on the safety group. Oventrop NT propelyne glycol antifreeze is filled into the closed loop system through the Regusol fill and flush valve.

Cold water is piped to the solar tank. An anti-scald valve must be installed for hot water mixing to hot water fixtures if the solar tank high limit in the Regusol controller is set above 120 °F. The top coil is piped to the boiler in the manner of a standard indirect water heater.

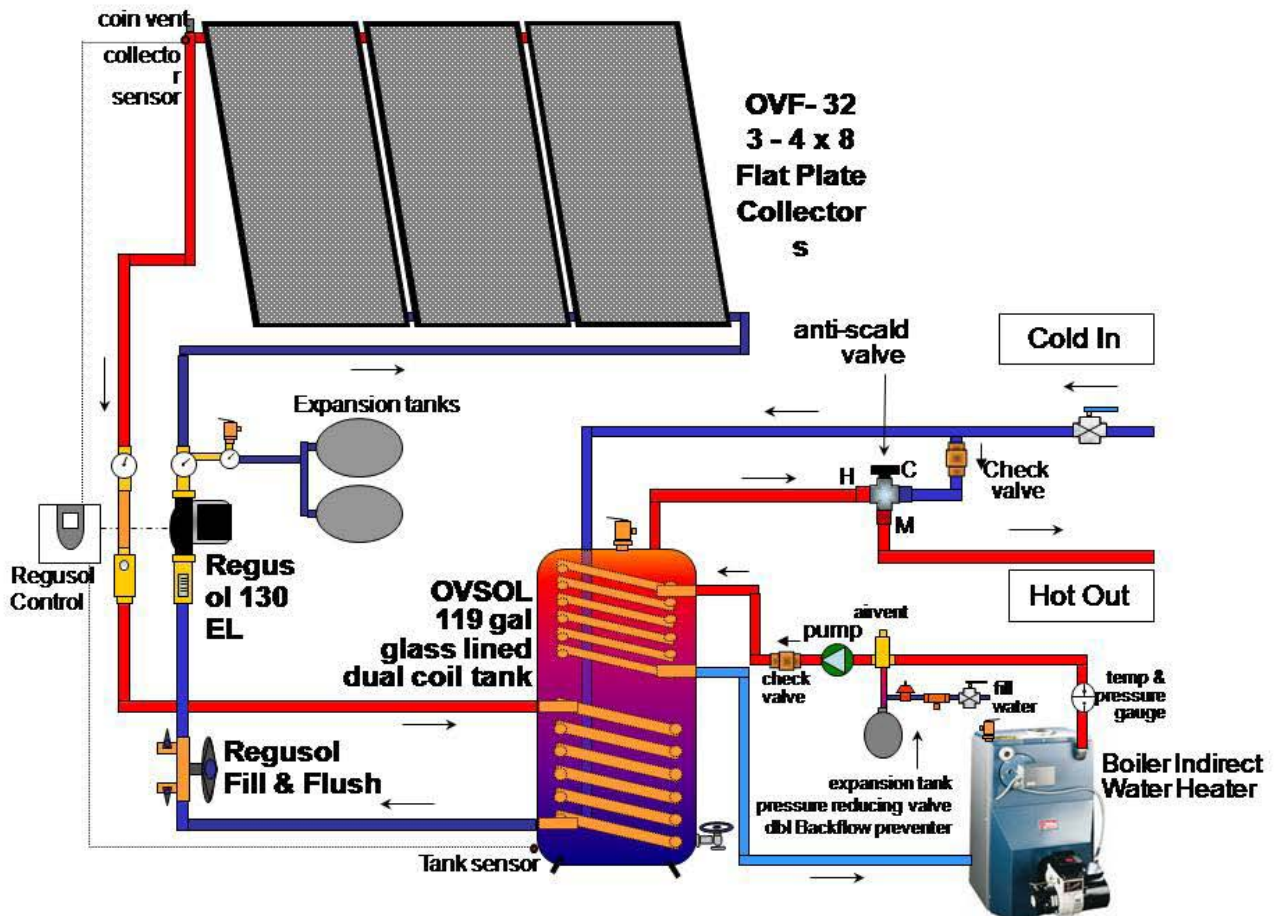

OVSOL System FP-3-DCE / 119 gallon, Flat plate, Dual coil electric tank

System Assembly

Installing OVSOL System FP-3-DCE
 Model Number 540 34 08K-DCE
 Solar Closed-Loop Domestic Hot Water System

Oventrop Components

Three OVF-32 Flat Plate Solar Collectors	filled weight: 675 lbs.
Regusol 130 EL Solar Transmission Station	filled weight: 20 lbs.
119 Gallon OVSOL glass lined Tank	filled weight: 1340 lbs.
Regusol Fill and Flush Valve	
Oventrop NT Propylene Glycol Antifreeze	

System Design Description

The solar closed-loop heating system consists of the Oventrop Regusol 130 EL pump and control station, one OV-5 evacuated tube collector, and an 119 gallon glass lined tank with two internal coils and an electric backup element. An expansion tank is installed at the Regusol on the safety group. Oventrop NT propylene glycol antifreeze is filled into the closed loop system through the Regusol fill and flush valve.

Cold water is piped to the solar tank. An anti-scald valve must be installed for hot water mixing to hot water fixtures if the solar tank high limit in the Regusol controller is set above 120 °F. The top coil is piped to the boiler in the manner of a standard indirect water heater.

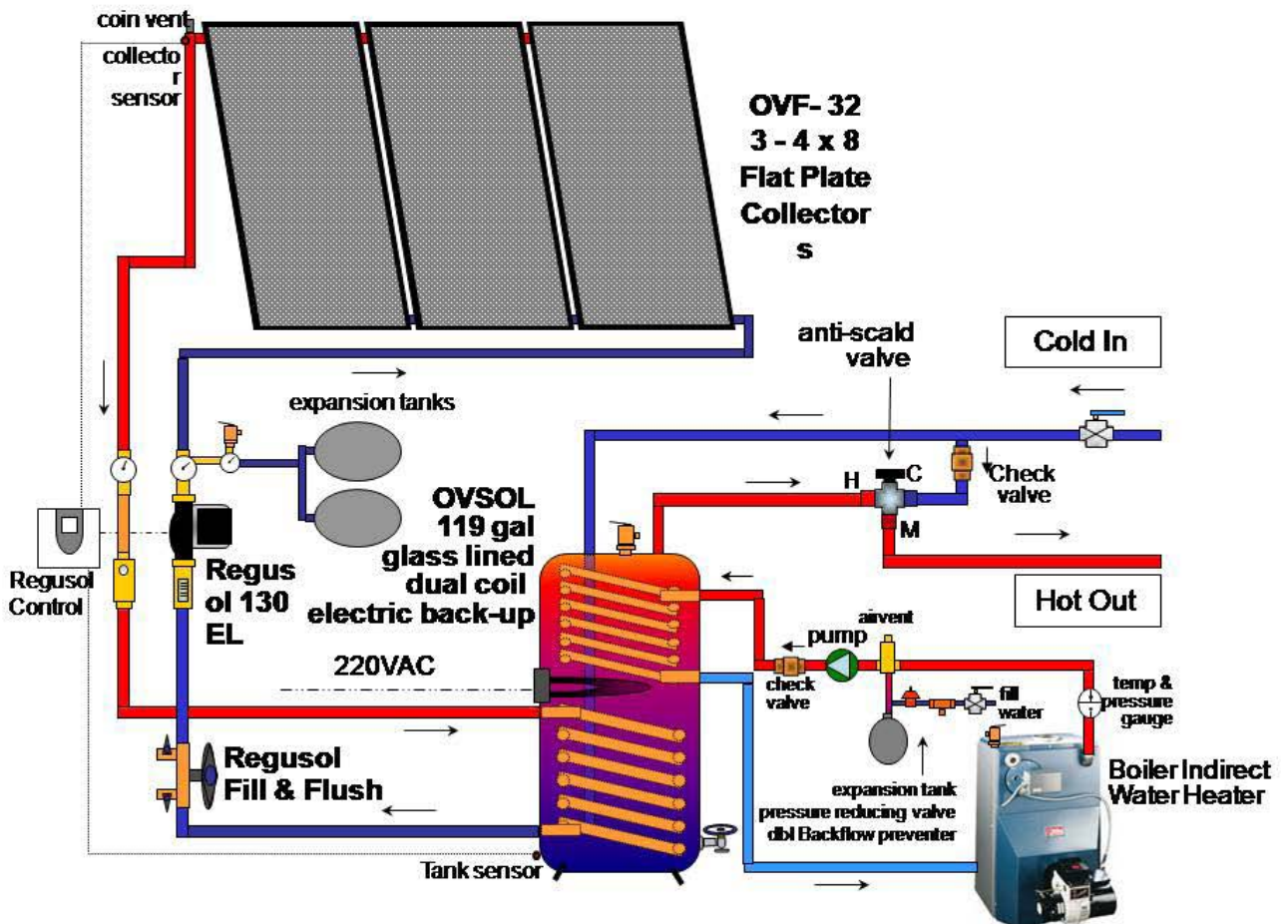

Piping the Solar Tank with Integrated Back-up as a One Tank System

Use 3/4" copper pipe for plumbing the tanks. To prevent heat loss through the copper tubing, insulate all tubing with at least 1/2" wall tube insulation. This should include the cold water feed to the solar storage tank up to 6 feet from the tank. A check valve should be installed on the cold water feed line to the mixing valve to prevent hot water migration into the cold water piping.

The solar tank should include valves and piping for service.

A domestic hot water expansion tank can be installed on the cold water feed to the tanks. The expansion tank should be installed downstream from a back flow preventer, for cold water feed to the tanks.

Service Valves and Instructions for Emergency

To isolate or service the hot water system in an emergency, turn system isolation valve #1 off.

To leave the system in an unoccupied house when hot water will not be drawn, the solar system should be drained of antifreeze and the controller turned to "off" or unplugged. You may also turn the system isolation valve #1 off if no hot water flow to the fixtures is desired.

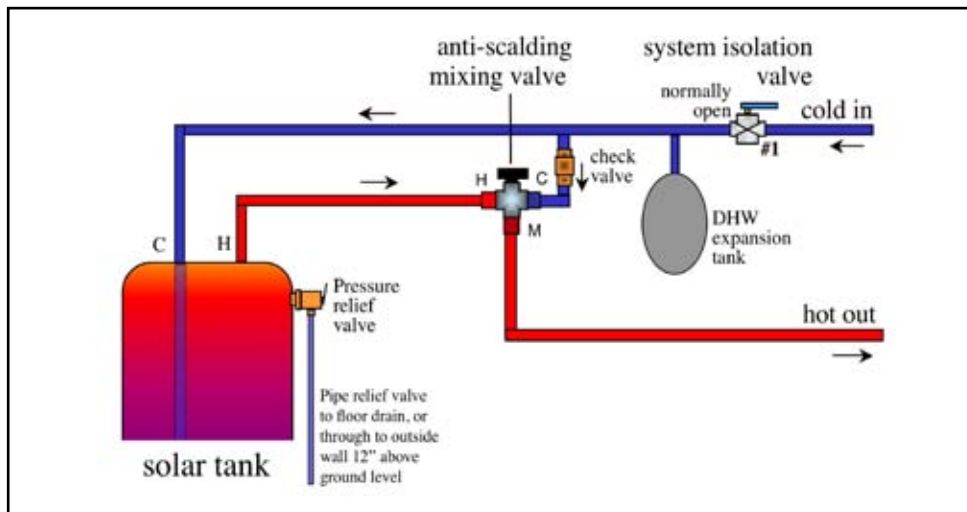

Piping the Solar Tank and the Auxiliary Hot Water Service for Two Tank System

Use 3/4" copper pipe for plumbing the tanks. To prevent heat loss through the copper tubing, insulate all tubing with at least 1/2" wall tube insulation. This should include the cold water feed to the solar storage tank up to 6 feet from the tank. A check valve should be installed on the cold water feed line to the mixing valve to prevent hot water migration into the cold water piping.

The solar tank should include valves and piping for service. In addition, the back-up water heater can have valves installed for solar hot water bypass.

A domestic hot water expansion tank can be installed on the cold water feed to the tanks. The expansion tank should be installed downstream from a back flow preventer, for cold water feed to the tanks.

Service Valves and Instructions for Emergency

To isolate or service the hot water system in an emergency, turn system isolation valve #1 off.

To isolate the solar tank from the auxiliary water heater, the normally open solar bypass valves #2 and #4 are shut off, isolating the solar tank from the supply of water. The normally closed valve #3 is then opened for bypass. Under no circumstances are valves number 1, 2 & 3 to be left open during solar operation.

To leave the system in an unoccupied house when hot water will not be drawn, the solar system should be drained of antifreeze and the controller turned to "off" or unplugged. You may also turn the system isolation valve #1 off if no hot water flow to the fixtures is desired.

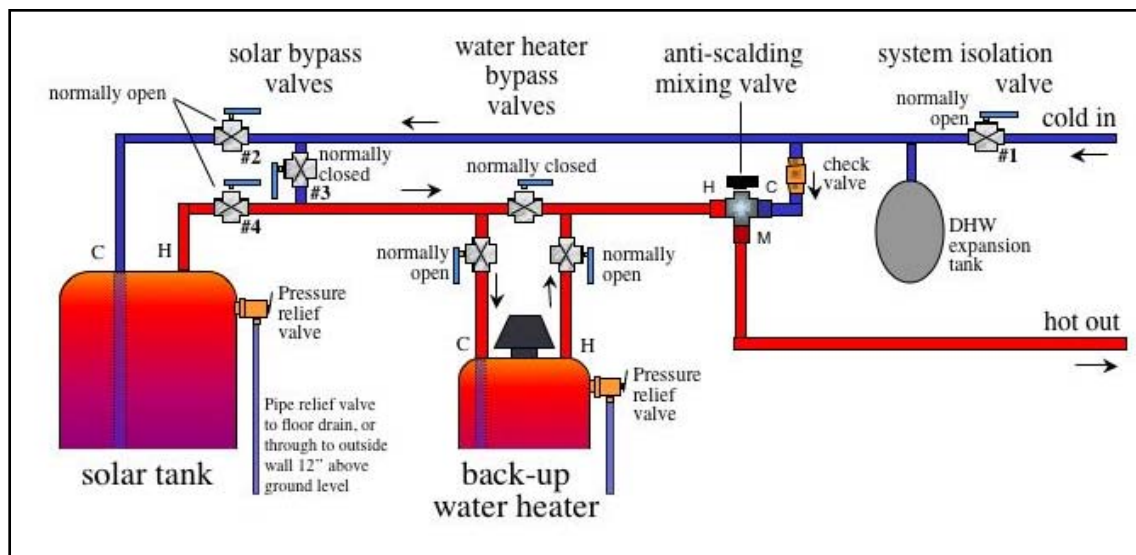

Piping and Insulating the Solar Loop

When piping collectors, use 3/4" copper for one to four 16-tube collector arrays. Preferably use type L. **Never use PEX plastic tubing. PEX tubing cannot withstand temperatures above 200°F, and fail in solar loops.**

Always insulate solar loops with at least a high temperature elastomeric insulation. This flexible rubber foam insulation may be protected against UV degradation with a mastic or a 15-year latex paint applied to the surface. High temperature fiberglass, urethane, and isocyanurates are also used on solar loops and have jackets that enclose and protect the insulation. Use insulation with at least a 3/4" wall thickness for all outdoor piping. Always insulate completely around pipe fittings and at the collector fittings. Pay particular attention to insulation detail at the collector sensor. Copper pipework must be supported by pipe hangers, split ring hangers or Unistrut clamps. Check your local codes for pipe sizes and support distances for vertical and horizontal runs. The supports must not hold onto and compress the insulation. Pipe support hangers should be secured directly to the pipe.

Oventrop Glass-lined Indirect Solar Hot Water Tanks

Indirect single and dual coil domestic hot water storage tanks are made in 80-, and 119-gallon models. Each tank has bottom heat exchanger coil connection for solar heat transfer with optional upper coil and electric backup elements.

Please read the Installation, Operating and Service Instructions Manual, placed with the tank.

Quality Design and Construction

Tanks and coils are all glass lined.

Includes over 2" of urethane insulation, R-14.

All tanks have a metal jacket over the insulation.

Electric Elements are 4500W ,240VAC.

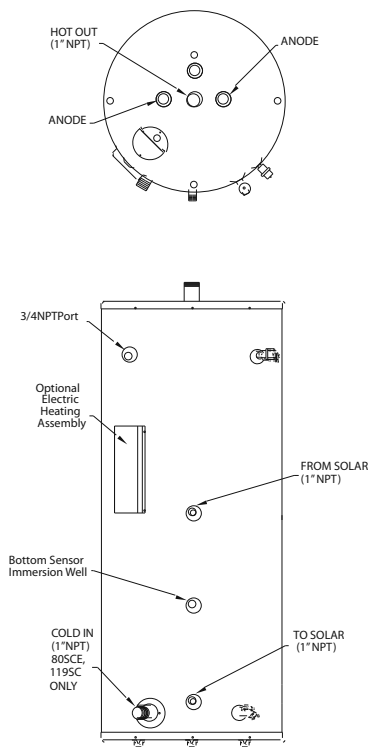

Figure 1: 80SC/SCE, 119SC/SCE

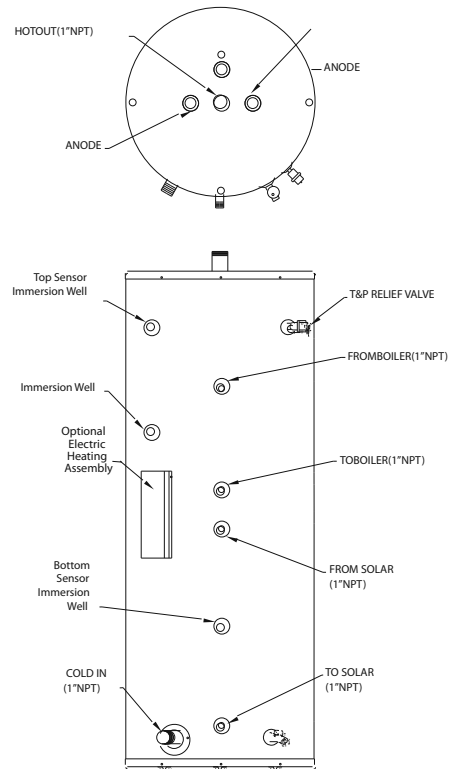

Figure 2: 80DC/DCE, 119DC/DCE

Locating the Water Heater

The water heater should be located in an area where water leakage from the tank or connections will not result in damage to areas adjacent to the water heater or to lower floors of the structure. When such a location cannot be avoided, a suitable drain pan must be installed under the water heater, and the drain pan must be connected to a drain.

The water heater should be installed as close to the back-up hot water heater or boiler as is practical for easy access for service.

The minimum clearances from combustible surfaces are:

Bottom-----0"
 Sides (non-piping) -----0"
 Front-----0"
 Top-----0"

The minimum clearances for service are:

Side (T&P Relief) ----- 6"
 Sides (non-piping) ----- 4"
 Front----- 16"
 Top----- 12"

Tank Dimensions:

	Dimensions (inches)	
	Height	Diameter
80 gallon	64	24
119 gallon	65	28

**Transmission station
with deaerator
“Regusol EL-130”
Installation instructions**

**Transmission station “Regusol EL-130” with pre-assembled,
integrated microprocessor-driven control.**

*The transmission station is supplied with a detailed
instruction manual of the control.*

*The “Regusol EL-130” is equipped with a deaerator for
air elimination from the heat transfer medium.*

Safety notes

The safety notes are to be observed.
Installation, initial operation, maintenance and repairs
have to be carried out by authorized and qualified trade persons.

Installation notes

The transmission station is supplied pre-assembled.
Pump wiring (5) is necessary.
Compression fittings for 3/4” copper pipe are included.
The transmission station always has to be mounted at a lower
level than the collectors.

Assembly notes

Remove transmission station from the packaging.
Pull the front insulation (1) from the control retainer (2)
while pushing the control retainer against the back insulation (3).
Now the control retainer can be pulled off the back insulation
together with the control (4).
Remove transmission station (6).

For each wall-mounting device (7), drill 5/16-inch holes
at a distance of 10 ⁵/₁₆ inches.
Fix mounting device by screwing it onto the wall and engage
back insulation. Now push transmission station onto the
fixing clips of the wall mounting device.

Connect the Regusol to the collectors (top connectors) and the tank
(bottom connectors) through the Regusol compression fittings.
See diagram 1 for details. Use 3/4” hard copper to pipe. The pipe
ends must be cut at right angles and be free of burrs. Apply clear
plumber’s grease on the compression nut thread and rings. Slide in
pipe until stop and firmly tighten the compression fittings. Hold firm
while tightening.
(Continued on next page)

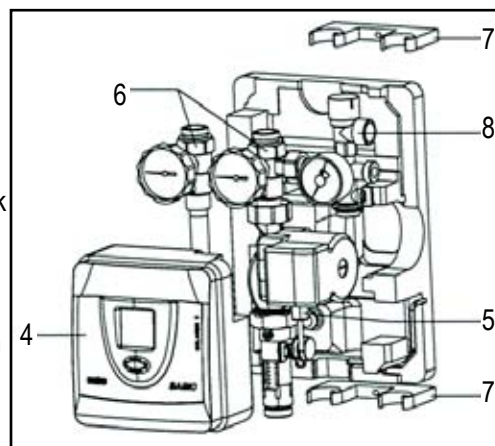
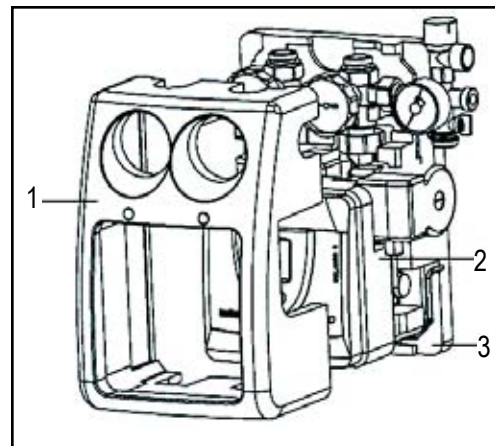
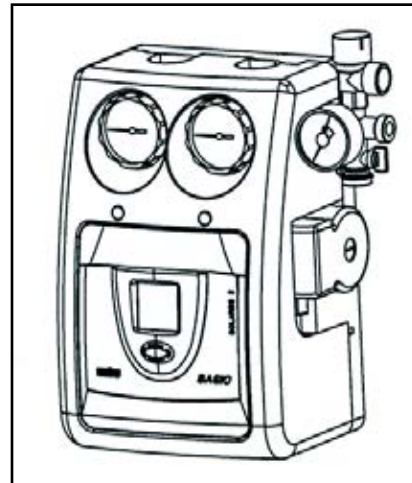

Screw safety group (8) onto the ball valve.
 Install discharging pipe from the pressure relief valve to the floor or through exterior wall to 12" from ground level.
 If there is no floor drain, a bucket may be placed under discharge pipe.
 Connect piping of 1/2" male pipe thread on the safety group to an expansion tank.
 Connect cable to the pump (diagram 2) and push control retainer with the control onto the back insulation.

Now the front insulation can be slipped over the control retainer and be pushed onto the back insulation until it clicks into position.

Air test all pipework on solar closed loop. Flush solar installation thoroughly, then fill the system with Oventrop solar fluid.
 Adjust the flow rate with the screw slot in the flow measuring device.

Open vent with radiator vent key on deaerator to remove any air separated from solar transfer fluid.

Make sure thermometers are left in their vertical position, as valve handles must be left open. Check that the screw slot on the supply side check valve is left in the horizontal position.

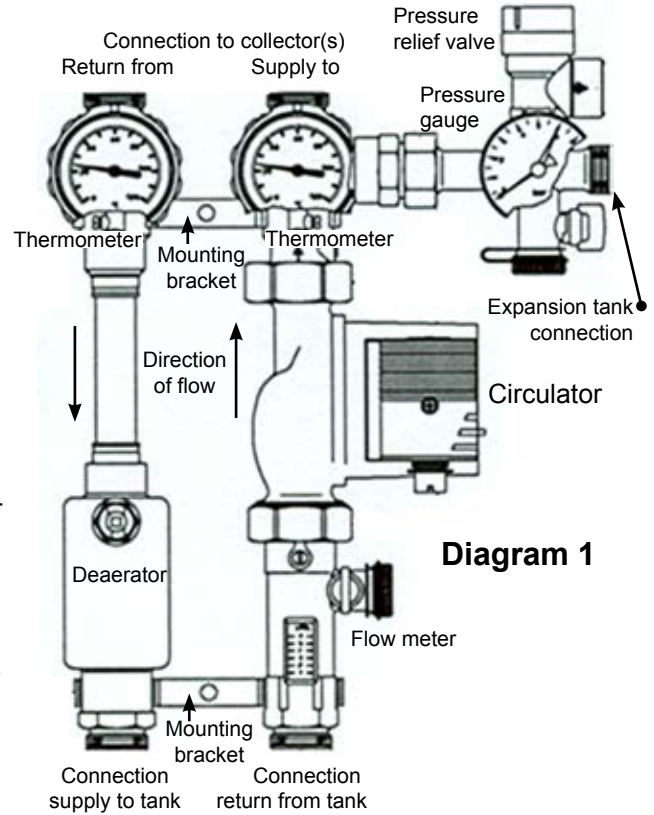
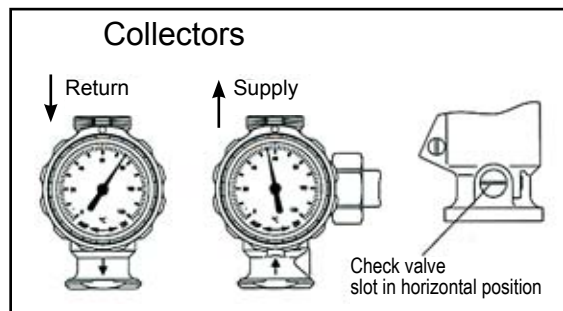
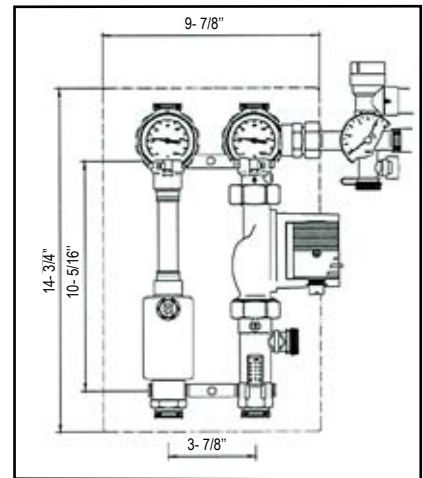
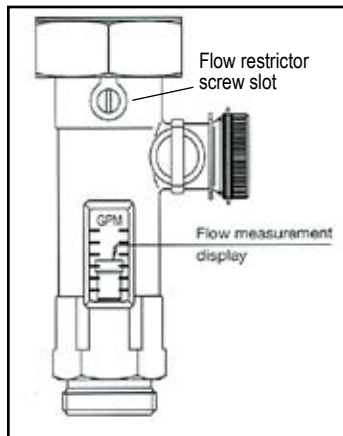

Diagram 1

Typical flow rates are set to 3/4 to 1 gpm per collector*
 *16 tube model collector



Thermometers in solar collection mode (displayed on the controller) will indicate a temperature rise on the return side of an average of 10 - 25° F. This temperature rise indicates that the collectors are collecting and transferring solar energy.

Oventrop Regusol 130 EL Controller Standard Solar Domestic Hot Water System Wiring

Warning!

Do not plug in Deltasol controller until all wiring connections are made.

The unit must only be located internally. It is not suitable for installation in wet or hazardous locations and should not be sited near any electromagnetic field. Sensor wires are installed separately from any 120 VAC power chords. The type of wire installed from the sensors to the controller should be sunlight-resistant shielded copper wire with at least two conductors at 18 AWG.

1. Unscrew the cross-recessed screw of the cover and remove it from the housing.
2. Wire the collector sensor and tank sensor wires (S1 & S2).
3. Wire the Regusol Wilo pump as follows:
 - yellow with green strip wire – ground
 - blue wire – neutral N #17
 - brown wire – hot R1 #18
4. Wire the outlet plug as follows:
 - green wire – ground
 - white wire – neutral N #19
 - black wire – load L #20
5. Replace cover.

The power supply to the controller must be made last.

Operating instructions are included with the solar controller.



- single relay differential controller
- sensor monitoring
- on/off/autocontrol
- operations hour counter

Wiring and operation instructions are included with the Regusol

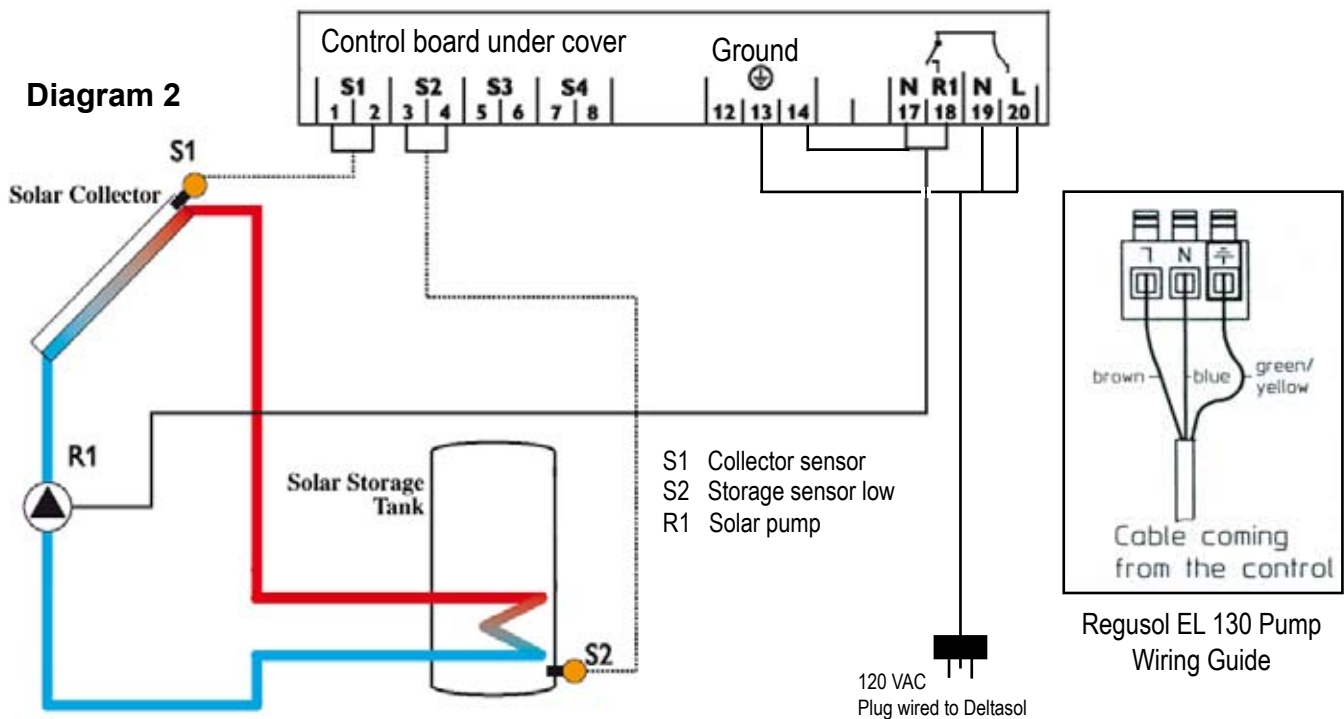

Operation and Programming the Regusol Controller

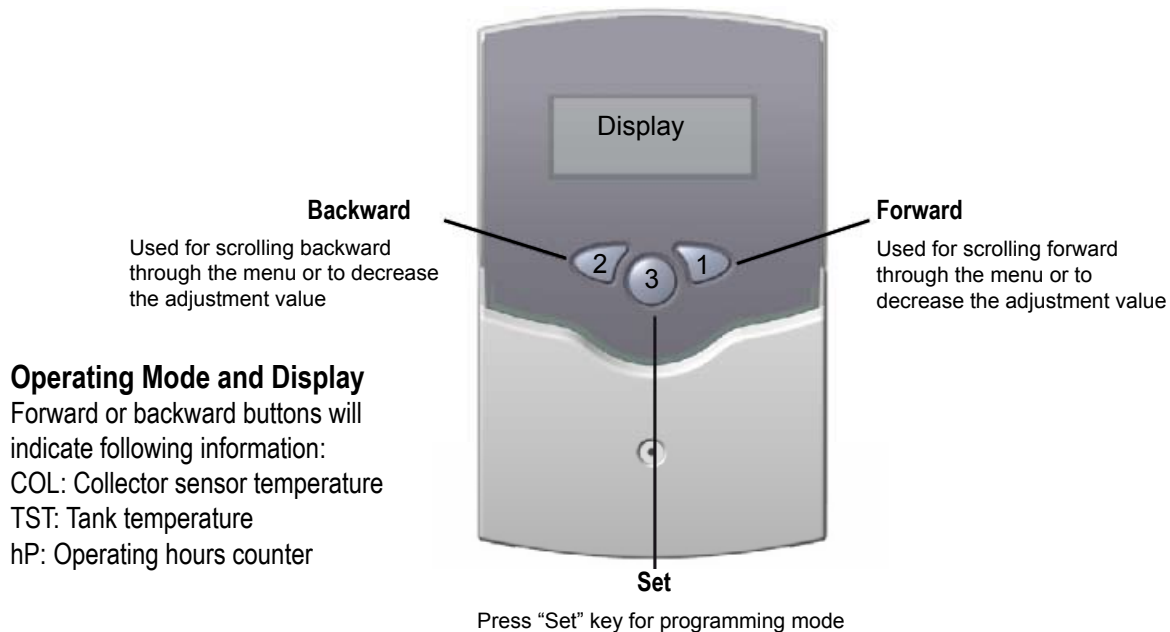

Programming Mode

To begin programming mode, press forward key to hP display.

Press and hold forward key 1 in "hP" mode for 2 seconds.

Menu mode displays next indicator (DT 0) and may now be scrolled through rest of programmable settings using keys 1 or 2 (forward or backward through the entire menu).

Values in display settings may be changed by pressing "Set" (key 3). The "Set" icon will blink while in programming mode. Raise or lower values with keys 1 or 2. Press set button once more to complete change. "Set" icon will stop blinking.

Program Changes

"DT 0" differential turn on set point

The first program display will be "DT 0" differential turn on set point. DT 0 is set at 12 °F. This indicates what turn on temperature the collectors must be above the tank to begin solar circulation. No change is necessary.

"DT F" differential turn off set point

The second indicator will be "DT F" differential turn off set point. DT F is set at 5 °F. This indicates what turn-off temperature the collectors must be above the tank for solar circulation to end. No change is necessary.

Program Changes

Mode of Operation ON / OFF / AUTO "HND 1"

Scroll through menu to "HND 1" display, near the end of the program menu. This is for the setting switch ON, OFF, or AUTO that allows the controller the function of operation. It is a service operation switch.

ON position energizes the pump to circulate at all times.
OFF position keeps the pump from circulating.
AUTO allows the controller to operate the pump based on the differential temperatures (normal operation).

Default setting is AUTO. To change press "Set" (key 3). Press key 1 or 2 to change into ON, OFF or AUTO mode. Press set key 3 again to complete change and before moving into the next menu.

Always leave the controller in AUTO for normal solar collection cycling.

"S MX" storage maximum set point

"S MX" is set at 140 °F. This setting can be turned up only if there is a anti-scald valve installed on the DHW system.

To change press "Set" (key 3). Press key 1 to increase or 2 to decrease the storage maximum temperature. Press set key again to set change.

Operating and Programming the Regusol Controller

Program Changes

The factory settings for the following displays are suitable for all solar domestic hot water heating. For more information on these settings, read the control manual included with the Regusol 130.

“EM” limit collector temperature

Factory setting: 285° F

“OCX” system cooling

Factory setting: OFF

“OCN” Minimum collector limitation

Factory setting: OFF

“OCF” antifreeze function

Factory setting: OFF

“OREC” option recooling

Factory setting: OFF

“O TC” tube collector special function

Factory setting: OFF

“OHQM” heat quantity balancing

Factory setting: OFF

The settings for the following displays are as follows.

“LANG” language

Factory setting: En (english)

“PROG”

Controllers program

“UNIT” Temperature in degrees

Factory setting: FAH (fahrenheit)

“VERS”

This indicates the program version

Section Seven

Collector Flush, Leak Check, and Fill Procedure

Before proceeding with the instructions outlined in this section, the solar storage tank should be filled with water. The collector loop then should be leak checked, flushed, and filled. A Regusol “fill and flush” valve should be installed for system charge-up. Filling or “charging up” a solar closed loop incorporates a 1/2 HP utility pump available through most Oventrop dealers.

Leak Check and Flush

1. To ensure there are no leaks, air test the system to approximately 60 PSI. Check and repair any leaks. When the solar loop is leak-free, release air and flush system with tap water.
2. Before filling the collector loop with antifreeze solution, it must be flushed free of any flux, copper filings, or debris. Straight tap water may be used for this purpose.
3. To perform this step, hook up a hose from tap faucet to the fill port and run another hose from the drain port to a drain or outdoors. Close center ball valve on “flush and fill.” Open water tap to begin flushing. Flush the system with tap water for approximately 10 minutes to assure there is no solder, flux, or debris left within the collector loop piping.

This step may also be used to cool the collectors before filling the system with propylene glycol.

Fill Procedure

Charging the collector loop will require approximately 3 - 8 gallons of Oventrop NT-40 antifreeze (provided). It is a premixed water-propylene glycol solution of 40% propylene glycol to 60% water and will provide freeze protection to -6 °F. **No mixing is necessary.**

If collector loop is to be charged during the sunlight hours, collectors should be covered for at least one hour before beginning; or the collector may be cooled with water using procedure in step 3 (above).

Connect pressure side of charge pump with washing machine hoses to the fill port. From suction side of charge pump, attach another hose to the bucket of the propylene glycol solution. Attach another hose from the drain port to an empty bucket. If the system was just flushed with water, drain down the water pressure to prime the charge pump. Drain water pressure into empty buckets.

Set up for filling with solar heat transfer fluid. Turn center ball valve of “Regusol fill and flush” perpendicular to have propylene glycol flow throughout solar closed loop.

Filling a Solar Closed Loop

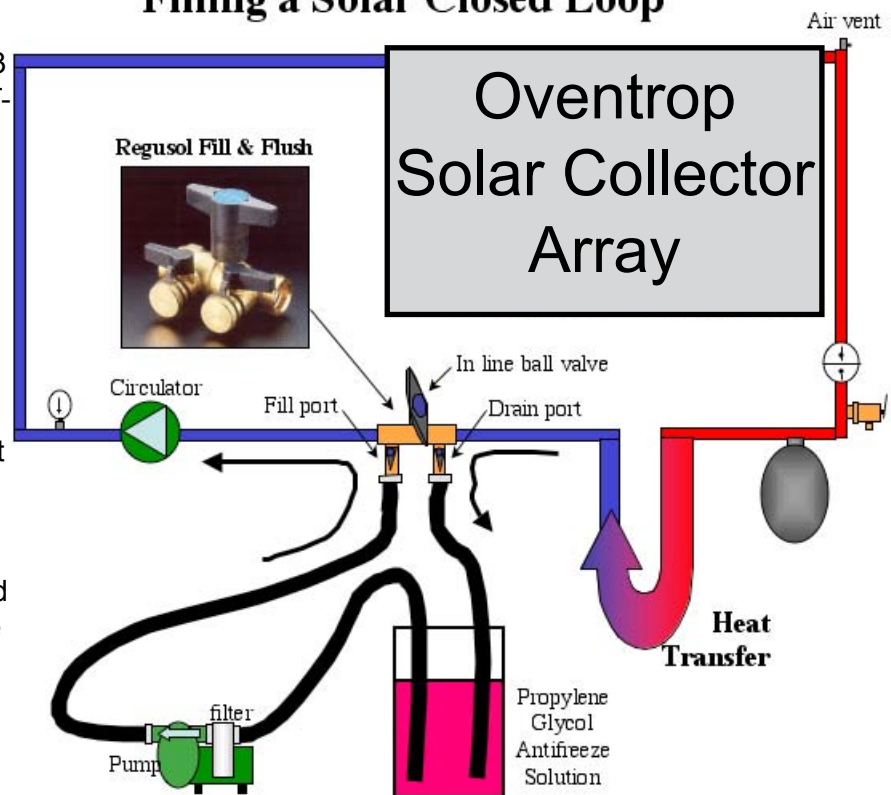

Turn on fill rig and pump propylene glycol. If pumping out water, have an empty bucket on the drain port hose to collect water until the color of antifreeze returns. Then put drain port hose into antifreeze bucket for circulating antifreeze. Run the charge pump until no air bubbles are seen returning to the bucket. Periodically close drain port to allow pressure to build, then reopen to purge any air that may be trapped. Watch for air escape. Repeat this procedure until air is no longer returning to the fill rig pail.

To complete system fill and charge, close the drain port and fill system to pressure of 30 to 35 psi. Close fill port and turn off charge pump. Turn center ball valve of "Regusol fill and flush" parallel to direction of flow to have propylene glycol flow throughout solar closed loop installation with the system pump in operation. Cover fill and drain ports with hose caps.

Open air vent atop solar collector to eliminate any air trapped at the high point of the system. Next open the air vent to remove air from the deaerator at the Regusol 130 EL.

Commissioning the System

Before activating system the following checks should be made:

- System filled with water (tank).
- Appropriate cold and hot water bypass valves are set for series water flow through tank(s).
- Collector and tank sensors connected.
- Regusol is wired and solar loop is air-tested for leaks.

The collector loop can now be filled with the recommended anti-freeze.

Once the solar loop is filled, place Regusol thermometer handles in the fully open position and the fill and flush valve in fully open position.

Plug in the Regusol controller for operation.

Controller will start and be in automatic mode of operation.

Digital display and indicator light should illuminate.

If the collector temperature is above the tank temperature by 12° F, the circulator should start and run. Flow meter will indicate circulation. If there is noise of air circulating through the pump, the system must be recharged to remove air bubbles. Solar closed loops must be free of air bubbles.

If the collector temperature is below the tank temperature, circulator should not run.

If circulator is not running, set the controller to the "On" position (see Operation and Controlling the Regusol Controller) to check circulator operation and indication of flow. Remember to leave the solar controller set in the "Auto" mode of operation when completed.

If circulator fails to operate, refer to Troubleshooting checks on the following pages.

It is unlikely that system malfunctions will develop within the Regusol. Should they occur, however, the following procedures will prove helpful. Several of the procedures indicated require the use of test equipment, such as a volt-ohmmeter with 10K scale. If this equipment is not available to you, contact your authorized Oventrop dealer or distributor for service.

Section Eight

1. Controller does not come on.	<ul style="list-style-type: none"> A. Controller is not plugged in B. Breaker tripped to off C. Blown fuse in controller D. Inoperative controller 	<ul style="list-style-type: none"> A. Check to see if plug is in outlet B. Reset breaker C. Replace fuse D. Replace controller
2. Circulator does not start or run in "on" position.	<ul style="list-style-type: none"> A. Shaft bound B. Blown fuse or breaker C. Bad electrical connection D. Inoperative controller 	<ul style="list-style-type: none"> A. Remove plug at rear of circulators and insert screw driver into slotted end of shaft; turn to loosen shaft B. Replace fuse; or reset breaker C. Tighten connections D. Replace controller
3. Circulators will not run with switch in "auto"	<ul style="list-style-type: none"> A. Same as A through D indicated above B. Inoperative sensor circuits C. Poorly attached or insulated sensors D. Inadequate temperature differential 	<ul style="list-style-type: none"> A. Same as A through D indicated above B. Check sensor circuits and wiring C. Reattach or reinsulate D. System will not operate until preset conditions are met
4. Circulator runs constantly in "auto"	<ul style="list-style-type: none"> A. Inoperative sensors or sensor wire circuits B. Inoperative controller 	<ul style="list-style-type: none"> A. Check sensor circuits and wiring, check for short in collector sensor circuit or open in tank sensor circuit Replace sensor wire or sensors B. Replace controller
5. Inadequate solar loop temperature.	<ul style="list-style-type: none"> A. Recent heavy usage of hot water C. Inoperative circulator D. Collector shading E. Ambient conditions F. Steam lock at solar collector 	<ul style="list-style-type: none"> A. Wait until system temperature is replenished C. Remove plug at rear of circulator and insert screwdriver into slotted end of shaft, turn to loosen shaft D. Remove shading obstacles E. Wait until preset conditions are met F. Recharge solar closed loop to remove air from antifreeze solution
6. System losing temperature at night.	<ul style="list-style-type: none"> A. Inoperative check valve(s) B. Inoperative controller C. Inoperative sensor circuits 	<ul style="list-style-type: none"> A. Make sure check valves in Regusol are not stuck open B. Replace controller C. Check sensor circuits and wiring

Trouble Shooting

Trouble	Probable Cause	Remedy
7. Inadequate hot water delivery temperature.	A. Recent heavy usage of hot water	A. Wait until system temperature is replenished
	B. Inoperative mixing valve	B. Adjust or replace mixing valve
	C. Ambient conditions	C. Wait until preset conditions are met
	D. Inoperative back-up hot water heater	D. Replace back-up tank or service thermostat or element in electric hot water heater (this should be done by licensed electrician)
	E. Inoperative existing system during periods of low solar insolation	E. Contact appropriate service
8. Tank pressure temperature relief valve blowing off.	A. Inoperative P/T relief valve	A. Replace P/T valve
	B. Hot water storage tanks building too much pressure	B. Install hot water expansion tank
	C. Water main pressure too high	C. Install Pressure regulator on cold water supply

Sensor Test

Use an Ohm meter to measure the resistance of the sensor circuit. If an open circuit or a short circuit situation is detected, then inspect the sensor wiring before suspecting the sensor. Measure the sensor resistance without the interconnecting wire before removing the sensor. The resistance should match the chart for a given temperature.

°F	Ω	°F	Ω
14	961	131	1213
23	980	140	1232
32	1000	149	1252
41	1019	158	1271
50	1039	167	1290
59	1058	176	1309
68	1078	185	1328
77	1097	194	1347
86	1117	203	1366
95	1136	212	1385
104	1155	221	1404
113	1175	230	1423
122	1194	239	1442

Resistance values of the Pt1000-sensors

Maintenance Procedures

Cleaning. The solar collectors will not require cleaning in a climate in which there is periodic rainfall. A light coating of dust will not seriously affect performance. In dry, dusty climates, collectors should be cleaned occasionally.

Circulators and Controller. No scheduled maintenance is required for the fluid lubricated circulators or controller system. In the event of a circulator or controller malfunction, refer to troubleshooting Checks.

Collector Loop Fluid. Collector loop fluid must be changed in order to maintain adequate freeze and corrosion protection. Antifreeze checks should be performed annually. Collector loop fluid should be replaced every 5 - 7 years. To prevent elevated temperatures from developing at the collectors, do not turn the system off while absent from premises for extended periods.

Solar Storage Tank. Periodically drain a small amount of water from the bottom of tank to prevent sludge or sediment buildup in the solar storage tank.

Scaling. If your water supply contains a large percentage of minerals (hard water), we strongly recommend that a water softening device be installed to protect not only the stainless steel solar storage tank and coils but also the existing hot water heater and its plumbing as well.

Projections for various components average life cycle

OVF-32 flat plate collectors 15 - 20 years
Dual or single coil indirect glass lined tanks: good water quality 20+ years
Regusol 130 EL: Oventrop PE Controller and sensors, Wilo circulator 10 - 15 years

All inquiries should be made to the product manufacturer:

Oventrop Corporation
PO Box 789
29 Kripes Road
East Granby, CT 06026
Ph. (860)413-9173
www.ventrop-us.com

Section Nine

Oventrop Corporation - Limited Warranty

Oventrop Corporation warrants to its “Customers” that all Oventrop products, used for heating and plumbing applications and sold in accordance with these warranty provisions, shall be free from defects in material and workmanship. “Customer” as used herein shall mean an end-user of Oventrop products.

Five (5) years for all solar components from the date of purchase, unless otherwise specified in writing.

Ten (10) years for evacuated tube collector from date of purchase, unless otherwise specified in writing.

Limited Lifetime for solar indirect water heater five (5) years from date of purchase, unless otherwise specified in writing.

In order to be eligible for a warranty claim, products sold

(1) must be installed and maintained professionally according to the relevant assembly instructions and the product manual,

(2) must only be used for purposes provided in the Oventrop Corporation’s product description or assembly instructions,

(3) must be exposed only to gaseous or liquid media approved for the product by Oventrop Corporation, and

(4) shall not be combined with products of other manufacturers unless otherwise stated in the product manual.

Oventrop Corporation’s sole obligation hereunder shall be, at its option, to issue credit, repair or replace any component or part thereof which is proved to be defective. The limited warranty does not cover cost for transportation or labor charges (including installation and removal) unless such charges are authorized in writing in advance by the Oventrop Corporation. Any repairs without the express written consent of Oventrop Corporation shall render this limited warranty invalid. Oventrop Corporation disclaims allowances for dismounting and consequential losses and damages.

Warranty claims must be received by Oventrop Corporation within the applicable warranty period and within thirty (30) days from when the cause for the claim occurred or was discovered. Upon receipt of prompt notice of a warranty claim, Oventrop Corporation shall have ten (10) business days in which to determine whether it acknowledges responsibility for any asserted defects in material or workmanship and the appropriate action to be taken.

This limited warranty and any claims arising from the breach of warranty, or any other claim arising hereunder, shall be governed and construed under the laws of the State of New York. No other persons than Oventrop Corporation employees have any expressed or implied authority to bind Oventrop Corporation to any agreement or warranty of any kind without the express written consent of Oventrop Corporation.

Disclaimer of Warranties:

OVENTROP CORPORATION DISCLAIMS ANY WARRANTY NOT PROVIDED HEREIN INCLUDING THE IMPLIED WARRANTY OF MERCHANTABILITY AND IMPLIED WARRANTY OF FITNESS FOR A PARTICULAR PURPOSE. IT IS EXPRESSLY UNDERSTOOD THAT OVENTROP CORPORATION IS NOT RESPONSIBLE FOR ANY CONSEQUENTIAL OR OTHER DAMAGES THAT MAY ARISE FROM USING OVENTROP CORP. SYSTEM COMPONENTS. DAMAGE RESULTING FROM WATER FREEZING IN THE TUBING DOES NOT CONSTITUTE A DEFECT IN MATERIAL OR WORKMANSHIP, AND SHALL NOT BE COVERED BY THIS WARRANTY. OVENTROP TUBING MAY NOT BE STORED IN DIRECT SUNLIGHT FOR ANY PERIOD LONGER THAN THREE WEEKS, OR THIS LIMITED WARRANTY BECOMES INVALID. OVENTROP CORPORATION DISCLAIMS ANY STATUTORY OR IMPLIED WARRANTY OF HABITABILITY. OVENTROP CORPORATION FURTHER DISCLAIMS ANY RESPONSIBILITY FOR LOSSES, EXPENSES, INCONVENIENCES, SPECIAL, INDIRECT, SECONDARY, INCIDENTAL, OR CONSEQUENTIAL DAMAGES ARISING FROM OWNERSHIP OR USE OF THE ARTICLES SOLD HEREUNDER.

THERE ARE NO WARRANTIES WHICH EXTEND BEYOND THE FACE HEREOF.