

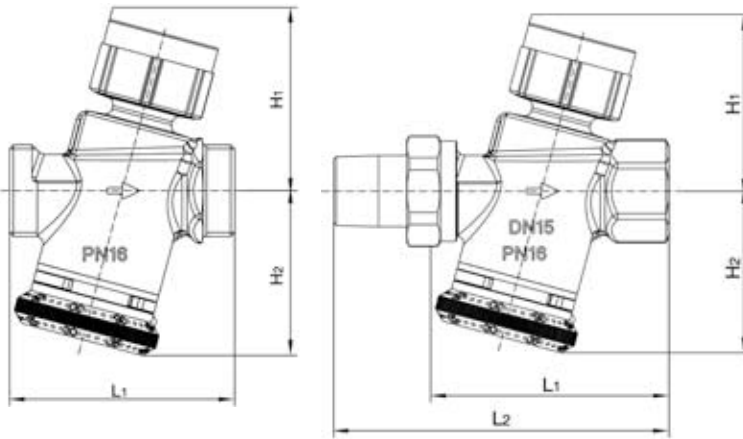

Oventrop

“Cocon Q”
Pressure independent control valve



Size:	L1	L2	H1	H2
1/2"	2.75	3.9	2.0	1.9
3/4" LF	2.9	4.2	2.0	1.9
3/4"	3.4	4.6	2.3	2.1
1"	4.6	6.1	2.6	3.1
1 1/4"	4.9	6.5	2.6	3.1

See back for dimensions with actuators

Minimum operating differential pressure

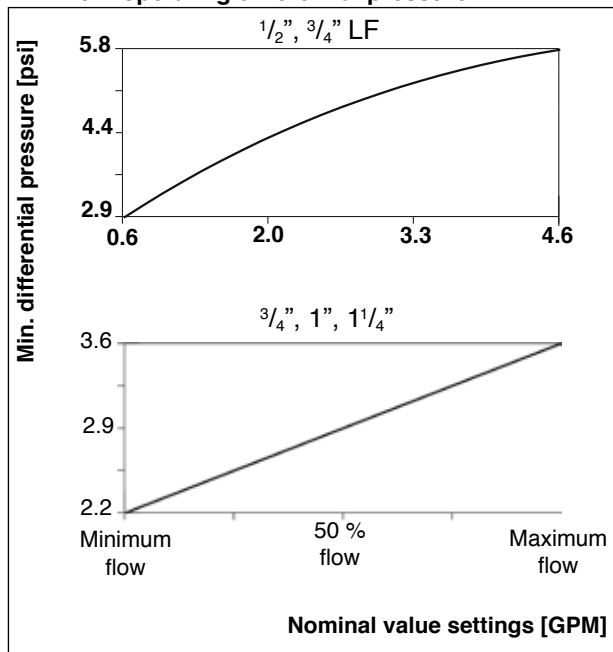

1

Product specification

Function:

The Oventrop pressure independent control valve “Cocon Q” maintains a valve authority of 100% and the desired flow over a wide range of differential pressures. The “Cocon Q” is ideal for variable flow applications and makes selection and commissioning easy. Select the valve with the flow range that satisfies the desired flow rate, and set the design flow rate on site with a quick turn of the hand wheel.

The valve is used for the hydronic balancing and temperature control of appliances or sections of the system in chilled ceiling, fan-coil, convector, central heating, and surface heating systems.

Performance data:

Maximum working temperature:	250°F (120°C)
Minimum working temperature:	14°F (-10°C)
Maximum working pressure:	232 psi (16 Bar)
Maximum differential pressure:	60 psi (4 Bar)
Minimum differential pressure:	3 to 6 psi (0.2 to 0.4 Bar)
Flow accuracy:	+/- 10%
Positioning accuracy:	0.1 GPM

Item numbers:

With test points		Item number	
Size	Flow range	Male/female ports	Male ports
1/2"	0.7 - 4.6 GPM	167 62 04	167 62 64
3/4" LF	0.7 - 4.6 GPM	167 60 06	167 60 66
3/4"	0.8 - 5.7 GPM	167 61 06	167 61 66
1"	1.3 - 8.8 GPM	167 61 08	167 61 68
1 1/4"	2.6 - 15.8 GPM	167 61 10	167 61 70

Accessories:

Lead sealing locking wire:	108 90 91
----------------------------	-----------

Oventrop Corporation
PO Box 789
East Granby, CT 06026
Phone: (860) 413-9173
www.oventrop-us.com

24V actuators with M30x1.5 connection

Item number	Model	Operating behavior (control signal)	Medium floating time	Maximum fluid temperature [F]	Allowable installation position	Actuator addition to H1 [in]
101 24 96*	Electrothermal, N.C., with end switch	On / Off	~ 4.5 minutes	212	Any	1.25
101 28 16*	Electrothermal, N.C.					
101 28 26*	Electrothermal, N.O.					
101 29 51*	Electrothermal, N.C.	0-10 V	~ 60 s/mm	203	Any, but not upside down	1.9
101 27 00	Electromotive, N.C. or N.O.	0-10 V, 0-5 V, 5-10 V	~ 15 s/mm			
101 27 01	Electromotive	Floating (3-point)				

*Not for use with 1" or 1 1/4" valves.



Construction:

The “Cocon Q” has a brass body and is alloyed to resist dezincification (DZR). No dielectric fittings are required for installation. The valve stem is stainless steel and the flexible components are made of EPDM and PTFE. The “Cocon Q” offers a hand wheel mounted opposite and inline with the actuator. The actuator and hand wheel are oriented 15 degrees from vertical to allow for easier operation. The valve has integral self-sealing ports for measuring differential pressure and fluid temperature using standard pressure and temperature test probes. Test ports are located perpendicular to the hand wheel, on the same side of the valve, and are replaceable with blind plugs if not needed. Test ports are spaced 1.0 inch apart and extend 1.5 inches from the valve body. The hand wheel is adjustable while the valve is in operation with the actuator installed. The “Cocon Q” includes a locking clip stop to ensure the balanced position while in operation and to prevent hand wheel repositioning after setting.

Proportional actuator characteristic lines

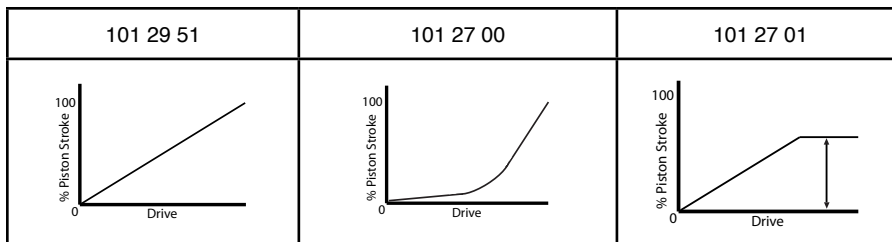

Valve characteristic line

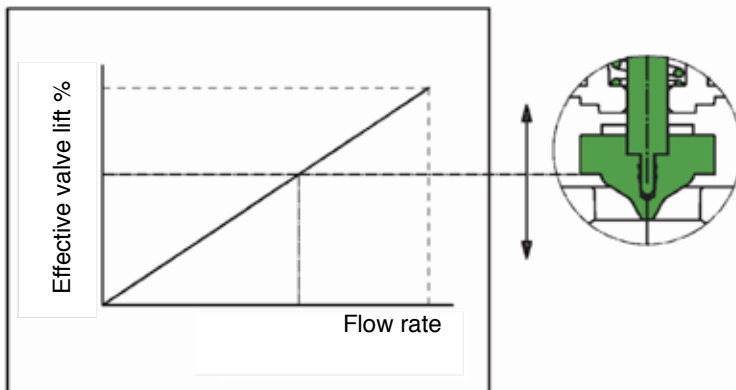

TYPICAL SPECIFICATIONS

Pressure independent control valves

½" (DN15) – 1¼" (DN32)

1.0 General – Furnish and install Oventrop balancing valves, as shown on the drawings and/or schedules, to ensure the accurate balancing of all flows in the hydronic heating and cooling systems. Water balancing and control shall meet the specified flows.

2.0 Construction

2.1 All control valves shall be of the pressure-independent design. All control valves shall have a constant control valve authority of 100% over the full allowable pressure and flow range. All control valves must offer a hand wheel mounted opposite and inline with the actuator. The actuator and hand wheel shall be oriented 15 degrees from vertical to allow for easier operation.

2.2 All control valves shall have documented measuring accuracy of +/- 10% within the normal setting range of the valve.

2.3 All control valves shall have integral self-sealing ports for measuring differential pressure and fluid temperature using standard pressure and temperature test probes. Test ports shall be located perpendicular to the hand wheel, on the same side of the valve, and shall be replaceable with blind plugs if not needed. Test ports shall be spaced no more than 1.0 inch apart and extend no more than 1.5 inches from the valve body.

2.4 All control valves shall have maximum body ratings no less than 232 psi (PN16) at 250 degrees F (120 C).

2.5 All control valves must include a locking clip stop to ensure the balanced position while in operation and to prevent hand wheel repositioning after setting.

2.6 All control valves ½" (DN15) through 1¼" (DN32) shall have hand wheel adjustment for precise readout on the opposite side of the valve from the actuator. The hand wheel shall be adjustable while the valve is in operation with the actuator installed. The hand wheel shall be marked in gallons per minute and shall have a minimum positioning accuracy of 0.1 GPM.

2.7 All control valves shall be manufactured by the company complying with international quality standard ISO 9001.

2.8 All control valves shall have a threaded connection of M30x1.5 for the actuator. All control valves shall have a stem travel of no less than 0.11 inches (2.8mm) over the full range of valve flow. All actuators shall be supplied by Oventrop. All actuators shall be capable of operating over the full flow and pressure range of the valve.

3.0 Material Characteristics – All control valves in sizes ½" (DN15) through 1¼" (DN32) shall have brass bodies and NPT threaded connections to match the piping system. All wetted brass parts shall be alloyed to resist dezincification (DZR). No dielectric fittings shall be required for installation. The valve stem shall be stainless steel. The flexible components shall be made of EPDM and PTFE.

4.0 Valve Sizing – All control valves shall be sized to perform in a normal operation range at a minimum differential pressure of 2.2 to 6 psi (0.15 to 0.4 Bar). All control valves shall have a maximum working differential pressure of no less than 60 psi (4 Bar). All control valves shall be selected based on their allowable flow range.

5.0 Manufacturer – Oventrop Corporation.

6.0 Warranty – Valves shall be free from material and workmanship defects for a period of 5 years from date of installation or from 5½ years from date of shipment, whichever comes first.

Oventrop reserves the right to make revisions to its products, their specifications, this bulletin, and related information without notice.

oventrop

Oventrop Corporation

PO Box 789 · 29 Kripes Road · East Granby, Connecticut 06026 · Phone 860-413-9173 · Fax 860-413-9436

“Hydrocontrol R”



“Hydrocontrol F”



“Hydrocontrol G”



NPT Connection	Solder Connection	DN	Size	Absolute Minimum Flow	Nominal Minimum Flow	Nominal Maximum Flow	Absolute Maximum Flow
				GPM			
106 10 04	106 05 51	15	1/2"	0.2	2.6	4.2	13.3
106 10 06	106 05 52	20	3/4"	0.3	3.4	6.2	19.5
106 10 08	106 05 53	25	1"	0.4	6.2	9.6	30.4
106 10 10	106 05 54	32	1 1/4"	0.4	9.4	21.0	66.6
106 10 12	106 05 55	40	1 1/2"	0.9	14.9	29.8	94.1
106 10 16	106 05 56	50	2"	2.1	22.4	42.0	132.7
Groove Connection	Flange Connection	DN	Size	Absolute Minimum Flow	Nominal Minimum Flow	Nominal Maximum Flow	Absolute Maximum Flow
				GPM			
-	106 29 46	20	3/4"	0.1	2.2	5.2	16.3
-	106 29 47	25	1"	0.4	5.1	9.1	28.7
-	106 29 48	32	1 1/4"	0.3	8.1	18.5	58.4
-	106 29 49	40	1 1/2"	0.7	12.3	29.1	92.0
-	106 29 50	50	2"	2.5	19.8	39.0	123.2
106 30 51	106 29 51	65	2 1/2"	1.5	38.9	106.0	335.3
106 30 52	106 29 52	80	3"	1.8	59.7	132.2	418.1
106 30 53	106 29 53	100	4"	2.6	100.6	217.5	687.7
106 30 54	106 29 54	125	5"	4.2	112.0	317.0	1002.5
106 30 55	160 29 55	150	6"	4.3	220.3	437.4	1383.3
106 30 56	106 29 56	200	8"	38.3	222.9	881.3	2786.8
106 30 57	106 29 57	250	10"	53.6	292.1	1298.4	4105.7
106 30 58	106 29 58	300	12"	153.0	616.7	1731.1	5474.3

The nominal ranges of the valves are based on the flow rates of the valves at a pressure drop of 2 [fthd] across the valve. The upper limit is set with the valve wide open and the lower limit is chosen so that any measurement taken at the valve will have a tolerance of no greater than +/- 5%. If the flow rate desired falls within the range of two different size valves, chose the smaller of the two valves. The absolute minimum is calculated assuming a pressure drop across the valve of 1 [fthd] with the valve set at the lowest presetting. The absolute maximum is calculated assuming a pressure drop across the valve of 20 [fthd] with the valve wide open.

oventrop

“Hydrocontrol R” Bronze
Double Regulating and Commissioning Valves
Thread Connection 1/2" - 2" (DN 15 - DN 50)

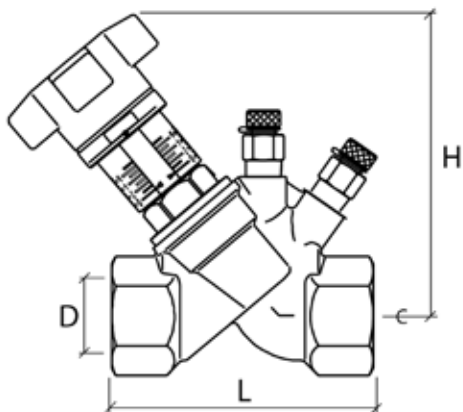

Dimensions in Inches

Size	Connection	Item no.	Weight	D	L	H	
DN15	1/2"	NPT	106 10 04	1.4 lbs.	1/2	3.15	4.49
DN20	3/4"	NPT	106 10 06	1.8 lbs.	3/4	3.31	4.57
DN25	1"	NPT	106 10 08	2.5 lbs.	1	3.84	4.69
DN32	1 1/4"	NPT	106 10 10	3.0 lbs.	1 1/4	4.33	5.35
DN40	1 1/2"	NPT	106 10 12	3.9 lbs.	1 1/2	4.72	5.43
DN50	2"	NPT	106 10 16	6.0 lbs.	2	5.91	5.83

Installation Notes

When installing the valves, it is to be observed that the direction of flow conforms with the arrow on the valve body and that the valve is installed with a minimum of 3 D (3 x nominal pipe diameter) of straight pipe at the valve inlet and of 2 D (2 x nominal pipe diameter) of straight pipe at the valve outlet.

The double regulating and commissioning valves may be installed in either the supply or the return pipe.



Product Specification

Oventrop double regulating and commissioning valves “Hydrocontrol R” are installed in the pipework of central hot water heating and cooling systems and serve to achieve a hydronic balance between the various circuits of the system.

The balance is achieved by a presetting with memory position. The calculated flow rate or pressure loss for each individual pipe can be preset centrally and regulated precisely. The required values of presetting can be obtained from the flow charts. All intermediate values are infinitely adjustable. The selected presetting can be read off two scales. The Oventrop double regulating and commissioning valves have two threaded ports which are equipped with the pressure test points for measuring the differential pressure.

Specifications:

Maximum working temperature: 300°F
Maximum working pressure: 235 psi
Temperature range: -4°F to 300°F

Bonnet, stem and disc made of bronze/dezincification resistant brass.
Disc with PTFE seal.
Double EPDM O-ring stem seal.

Oventrop Corporation
PO Box 789
East Granby, CT 06026
Phone: (860) 413-9173
www.oventrop-us.com

“Hydrocontrol R”
Sweat or Thread Connection
1/2” to 2” Valves

Cv Values for Various Handwheel Settings

Presetting or Handwheel Turns	1/2”	3/4”	1”	1 1/4”	1 1/2”	2”
0.5	0.40	0.58	1.08	1.20	3.09	3.13
1.0	0.53	0.84	1.77	2.40	4.80	5.88
1.5	0.66	1.08	2.42	3.37	6.67	8.31
2.0	0.84	1.33	3.00	4.67	8.53	10.66
2.5	1.14	1.57	3.59	5.91	10.12	13.55
3.0	1.56	1.86	4.29	6.98	11.65	16.55
3.5	1.98	2.37	5.14	7.97	13.02	19.01
4.0	2.38	3.00	6.00	8.88	14.37	21.51
4.5	2.77	3.63	6.92	10.06	16.05	24.07
5.0	3.14	4.24	7.81	11.27	17.74	26.66
5.5	3.56	4.97	8.51	12.44	20.17	28.49
6.0	3.95	5.69	9.20	13.60	22.62	30.04
6.5	4.33	6.33	9.78	14.88	24.36	32.27
7.0	4.51	6.64	10.34	16.17	26.10	34.20
7.5	-	-	-	17.47	27.47	36.16
8.0	-	-	-	18.73	28.86	38.06
8.5	-	-	-	19.97	29.59	40.35
9.0	-	-	-	21.14	30.34	42.65
9.5	-	-	-	22.01	31.16	44.13
10.0	-	-	-	22.62	31.99	45.09

“Hydrocontrol” Valve Accessories



Set of 2 pressure test points
Item 106 02 81



Extension piece for pressure test points
40mm Item 168 83 95
80mm Item 106 02 95



Fill and drain ball valve 1/4”
Item 106 01 91

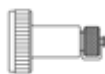

Measuring adapter
for fill and drain ball valve
Item 106 02 98

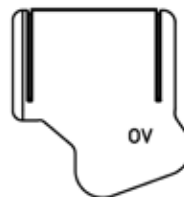

Insulation shell
for “Hydrocontrol R”

Size	Item no.
DN15 1/2”	106 00 81
DN20 3/4”	106 00 82
DN25 1”	106 00 83
DN32 1 1/4”	106 00 84
DN40 1 1/2”	106 00 85
DN50 2”	106 00 86



Flow meter
OV-DMC 2
Item 106 91 77

oventrop

“Hydrocontrol R” Bronze
Double Regulating and Commissioning Valves
Sweat Connection 1/2” - 2” (DN 15 - DN 50)

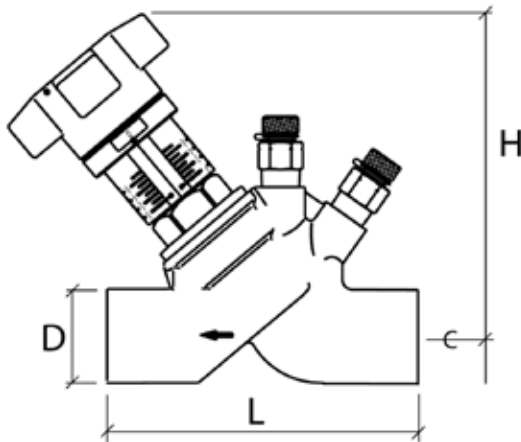

Dimensions in Inches

Size	Connection	Item no.	Weight	D	L	H	
DN15	1/2"	solder	106 05 51	1.4 lbs.	1/2	3.50	4.49
DN20	3/4"	solder	106 05 52	1.6 lbs.	3/4	3.81	4.57
DN25	1"	solder	106 05 53	1.8 lbs.	1	4.31	4.69
DN32	1 1/4"	solder	106 05 54	3.1 lbs.	1 1/4	5.06	5.35
DN40	1 1/2"	solder	106 05 55	3.8 lbs.	1 1/2	5.56	5.43
DN50	2"	solder	106 05 56	5.3 lbs.	2	6.56	5.83

Installation Notes

When installing the valves, it is to be observed that the direction of flow conforms with the arrow on the valve body and that the valve is installed with a minimum of 3 D (3 x nominal pipe diameter) of straight pipe at the valve inlet and of 2 D (2 x nominal pipe diameter) of straight pipe at the valve outlet.

The double regulating and commissioning valves may be installed in either the supply or the return pipe.



Product Specification

Oventrop double regulating and commissioning valves “Hydrocontrol R” are installed in the pipework of central hot water heating and cooling systems and serve to achieve a hydronic balance between the various circuits of the system.

The balance is achieved by a presetting with memory position. The calculated flow rate or pressure loss for each individual pipe can be preset centrally and regulated precisely. The required values of presetting can be obtained from the flow charts. All intermediate values are infinitely adjustable. The selected presetting can be read off two scales. The Oventrop double regulating and commissioning valves have two threaded ports which are equipped with the pressure test points for measuring the differential pressure.

Specifications:

Maximum working temperature: 300°F

Maximum working pressure: 235 psi

Temperature range: -4°F to 300°F

Bonnet, stem and disc made of bronze/dezincification resistant brass.

Disc with PTFE seal.

Double EPDM O-ring stem seal.

Oventrop Corporation
PO Box 789
East Granby, CT 06026
Phone: (860) 413-9173
www.oventrop-us.com

“Hydrocontrol R”
Sweat or Thread Connection
1/2” to 2” Valves

Cv Values for Various Handwheel Settings

Presetting or Handwheel Turns	1/2”	3/4”	1”	1 1/4”	1 1/2”	2”
0.5	0.40	0.58	1.08	1.20	3.09	3.13
1.0	0.53	0.84	1.77	2.40	4.80	5.88
1.5	0.66	1.08	2.42	3.37	6.67	8.31
2.0	0.84	1.33	3.00	4.67	8.53	10.66
2.5	1.14	1.57	3.59	5.91	10.12	13.55
3.0	1.56	1.86	4.29	6.98	11.65	16.55
3.5	1.98	2.37	5.14	7.97	13.02	19.01
4.0	2.38	3.00	6.00	8.88	14.37	21.51
4.5	2.77	3.63	6.92	10.06	16.05	24.07
5.0	3.14	4.24	7.81	11.27	17.74	26.66
5.5	3.56	4.97	8.51	12.44	20.17	28.49
6.0	3.95	5.69	9.20	13.60	22.62	30.04
6.5	4.33	6.33	9.78	14.88	24.36	32.27
7.0	4.51	6.64	10.34	16.17	26.10	34.20
7.5	-	-	-	17.47	27.47	36.16
8.0	-	-	-	18.73	28.86	38.06
8.5	-	-	-	19.97	29.59	40.35
9.0	-	-	-	21.14	30.34	42.65
9.5	-	-	-	22.01	31.16	44.13
10.0	-	-	-	22.62	31.99	45.09

“Hydrocontrol” Valve Accessories



Set of 2 pressure test points
Item 106 02 81



Extension piece for pressure test points
40mm Item 168 83 95
80mm Item 106 02 95



Fill and drain ball valve 1/4”
Item 106 01 91

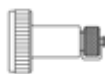

Measuring adapter
for fill and drain ball valve
Item 106 02 98

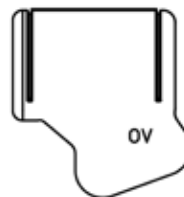

Insulation shell
for “Hydrocontrol R”

Size	Item no.
DN15 1/2”	106 00 81
DN20 3/4”	106 00 82
DN25 1”	106 00 83
DN32 1 1/4”	106 00 84
DN40 1 1/2”	106 00 85
DN50 2”	106 00 86



Flow meter
OV-DMC 2
Item 106 91 77

oventrop

“Hydrocontrol F” Cast Iron
Double Regulating and Commissioning Valves
Flanged Connection $\frac{3}{4}$ " - 12" (DN 20 - DN 300)

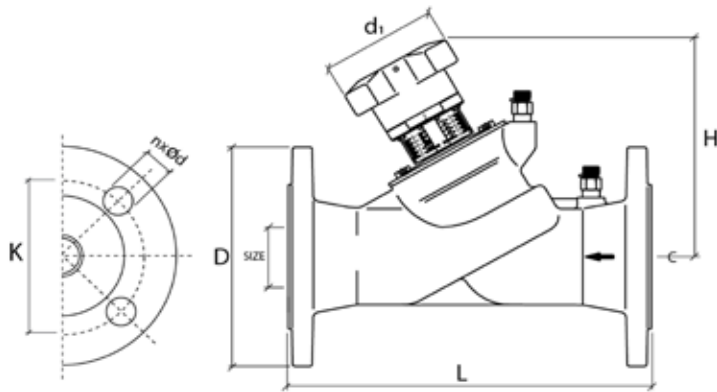

Dimensions in Inches

Size	Item no.	Weight	L	H max.	d1	D	K	n x Ød
DN20 $\frac{3}{4}$ "	106 29 46	7.5 lbs.	5.91	4.65	2.76	4.13	2.75	0.16x0.62
DN25 1"	106 29 47	7.8 lbs.	6.30	4.65	2.76	4.53	3.12	0.16x0.62
DN32 $1\frac{1}{4}$ "	106 29 48	12.8 lbs.	7.09	5.35	2.76	5.51	3.50	0.16x0.62
DN40 $1\frac{1}{2}$ "	106 29 49	13.7 lbs.	7.87	5.35	2.76	5.91	3.88	0.16x0.62
DN50 2"	106 29 50	18.6 lbs.	9.06	5.71	2.76	6.50	4.75	0.16x0.75
DN65 $2\frac{1}{2}$ "	106 29 51	31.7 lbs.	11.4	7.4	4.33	7.28	5.50	0.16x0.75
DN80 3"	106 29 52	39.8 lbs.	12.2	8.0	4.33	7.83	6.0	0.31x0.75
DN100 4"	106 29 53	61.3 lbs.	13.8	9.45	6.3	8.66	7.50	0.31x0.75
DN125 5"	106 29 54	89.9 lbs.	15.8	11.1	6.3	9.84	8.50	0.31x0.88
DN150 6"	106 29 55	113.9 lbs.	18.9	11.2	6.3	11.2	9.50	0.31x0.88
DN200 8"	106 29 56	361.9 lbs.	23.6	18.4	11.8	13.4	11.75	0.47x1.0
DN250 10"	106 29 57	431.2 lbs.	28.7	18.9	11.8	15.9	14.25	0.47x1.0
DN300 12"	106 29 58	581.9 lbs.	33.5	20.3	11.8	18.1	17.0	0.47x1.0
DN350 14"	106 29 59	770.0 lbs.	38.6	22.1	11.8	20.5	18.75	0.63x1.12

Installation Notes

When installing the valves, it is to be observed that the direction of flow conforms with the arrow on the valve body and that the valve is installed with a minimum of 3 D (3 x nominal pipe diameter) of straight pipe at the valve inlet and of 2 D (2 x nominal pipe diameter) of straight pipe at the valve outlet.

The double regulating and commissioning valves may be installed in either the supply or the return pipe.



Oventrop Corporation
PO Box 789
East Granby, CT 06026
Phone: (860) 413-9173
www.oventrop-us.com

Product Specification

Oventrop double regulating and commissioning valves “Hydrocontrol F” are installed in the pipework of central hot water heating and cooling systems and serve to achieve a hydronic balance between the various circuits of the system.

The balance is achieved by a presetting with memory position. The calculated flow rate or pressure loss for each individual pipe can be preset centrally and regulated precisely. The required values of presetting can be obtained from the flow charts. All intermediate values are infinitely adjustable. The selected presetting can be read off two scales. The Oventrop double regulating and commissioning valves have two threaded ports which are equipped with the pressure test points for measuring the differential pressure.

Specifications:

Maximum working temperature: 300°F
Maximum working pressure: 235 psi
Temperature range: 15°F to 300°F

Valve bodies manufactured from cast iron to ASME/ANSI B16.5 and flanged to 125 lb. standards. Valve body made of cast iron (GG 25 EN-GJL-250), hole circle of the flanged connection according to ANSI 150.

Bonnet, stem and disc made of bronze/dezincification resistant brass.
Disc with PTFE seal.
Double EPDM O-ring stem seal.

**Hydrocontrol F—Flanged Connection— $\frac{3}{4}$ " to 12" valves
Cv Values for Various Handwheel Settings**

Presetting or Handwheel Turns	$\frac{3}{4}$ "	1"	1 $\frac{1}{4}$ "	1 $\frac{1}{2}$ "	2"	2 $\frac{1}{2}$ "	3"	4"	5"	6"	8"	10"	12"
0.5	0.26	0.97	0.97	1.94	3.83	2.21	2.67	3.96	6.40	6.50	-	-	-
1.0	0.49	1.55	2.01	3.80	6.70	4.19	5.12	9.94	14.48	17.70	-	-	-
1.5	0.73	2.13	3.12	5.55	8.42	6.51	8.14	16.28	22.56	29.37	-	-	-
2.0	0.97	2.72	4.22	7.21	11.10	11.63	13.78	21.51	30.93	41.00	56.86	81.4	232.56
2.5	1.21	3.29	5.33	8.59	13.45	17.44	21.69	27.91	40.41	62.70	72.09	98.84	290.70
3.0	1.45	3.86	6.43	10.10	15.59	27.91	30.35	41.16	55.52	110.49	97.67	127.91	360.47
3.5	1.79	4.63	7.57	11.59	18.09	39.53	40.70	60.47	73.66	157.50	132.56	174.42	441.86
4.0	2.33	5.51	8.67	13.23	21.33	50.58	52.03	83.72	94.24	194.33	175.58	226.74	558.14
4.5	2.95	6.51	9.85	14.99	23.90	60.47	64.19	108.14	120.41	236.80	239.53	313.95	662.79
5.0	3.59	7.72	10.99	16.87	26.40	70.93	75.12	130.23	149.13	277.80	302.67	413.95	767.44
5.5	4.22	8.65	12.33	19.33	28.84	81.41	87.73	153.29	184.53	316.74	372.09	511.63	872.09
6.0	4.85	9.19	13.60	22.24	31.26	90.70	101.16	172.09	215.47	349.30	445.35	606.98	982.56
6.5	5.30	9.53	14.90	24.30	32.92	98.84	113.43	190.73	253.55	379.88	555.58	705.81	1069.77
7.0	5.55	9.74	15.87	25.93	34.51	104.65	124.13	208.15	283.90	413.49	592.44	793.02	1151.16
7.5	-	-	16.63	27.29	35.91	109.88	133.14	220.98	311.80	444.19	650.00	883.72	1244.19
8.0	-	-	17.28	28.50	37.21	113.95	142.09	233.72	340.70	470.12	718.60	976.74	1325.58
8.5	-	-	17.93	29.26	38.44	-	-	-	-	-	767.44	1034.88	1406.98
9.0	-	-	18.57	29.97	39.60	-	-	-	-	-	842.44	1084.88	1500.00
9.5	-	-	19.22	30.63	40.70	-	-	-	-	-	881.98	1139.53	1569.77
10.0	-	-	19.86	31.26	41.86	-	-	-	-	-	894.19	1195.35	1651.16
10.5	-	-	-	-	-	-	-	-	-	-	906.98	1255.81	1720.93
11.0	-	-	-	-	-	-	-	-	-	-	918.60	1302.33	1779.07
11.5	-	-	-	-	-	-	-	-	-	-	931.86	1348.84	1825.58
12.0	-	-	-	-	-	-	-	-	-	-	947.09	1395.35	1860.47

“Hydrocontrol” Valve Accessories



Set of 2 pressure test points
Item 106 02 81



Extension piece for pressure test points
40mm Item 168 83 95
80mm Item 106 02 95

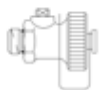

Fill and drain ball valve $\frac{1}{4}$ "
Item 106 01 91

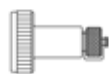

Measuring adapter
for fill and drain ball valve
Item 106 02 98

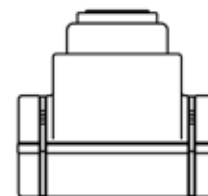

Insulation shell
for “Hydrocontrol F” & “G”

Size	Item no.
DN20 $\frac{3}{4}$ "	106 25 81
DN25 1"	106 25 82
DN32 1 $\frac{1}{4}$ "	106 25 83
DN40 1 $\frac{1}{2}$ "	106 25 84
DN50 2"	106 25 85
DN65 2 $\frac{1}{2}$ "	106 25 86
DN80 3"	106 25 87
DN100 4"	106 25 88
DN125 5"	106 25 89
DN150 6"	106 25 90



Flow meter
OV-DMC 2
Item 106 91 77

Oventrop Corporation
PO Box 789
East Granby, CT 06026
Phone: (860) 413-9173
www.oventrop-us.com

oventrop

“Hydrocontrol G” Cast Iron
Double Regulating and Commissioning Valves
Grooved Connection 2 1/2” - 12” (DN 65 - DN 300)

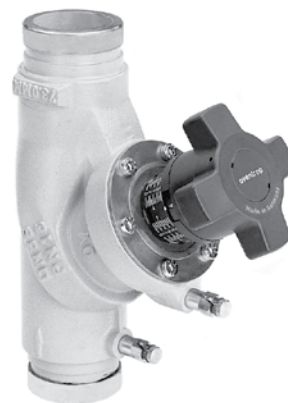
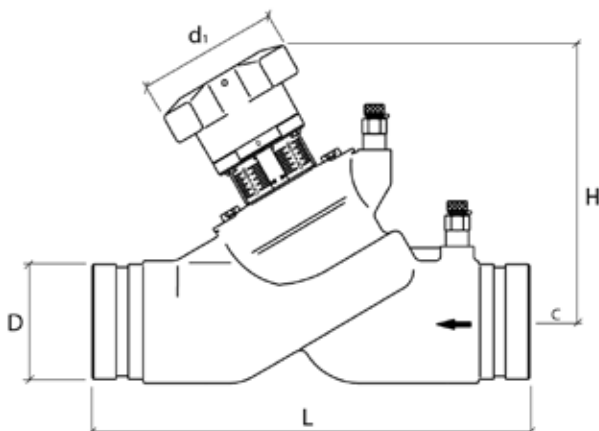

Dimensions in Inches

Size	Item no.	Weight	L	H	D	d1
DN65 2 1/2"	106 30 51	19.6 lbs	11.4	7.4	2.9	4.3
DN80 3"	106 30 52	27.8 lbs	12.2	8.0	3.5	4.3
DN100 4"	106 30 53	45.2 lbs	13.8	9.45	4.5	6.3
DN125 5"	106 30 54	70.0 lbs	15.8	11.1	5.6	6.3
DN150 6"	106 30 55	95.7 lbs	18.9	11.2	6.6	6.3
DN200 8"	106 30 56	255.2 lbs	23.6	18.4	8.6	11.8
DN250 10"	106 30 57	377.3 lbs	28.7	18.9	10.8	11.8
DN300 12"	106 30 58	520.3 lbs	33.5	20.3	12.9	11.8

Installation Notes

When installing the valves, it is to be observed that the direction of flow conforms with the arrow on the valve body and that the valve is installed with a minimum of 3 D (3 x nominal pipe diameter) of straight pipe at the valve inlet and of 2 D (2 x nominal pipe diameter) of straight pipe at the valve outlet.

The double regulating and commissioning valves may be installed in either the supply or the return pipe.



Product Specification

Oventrop double regulating and commissioning valves “Hydrocontrol G” are installed in the pipework of central hot water heating and cooling systems and serve to achieve a hydronic balance between the various circuits of the system.

The balance is achieved by a presetting with memory position. The calculated flow rate or pressure loss for each individual pipe can be preset centrally and regulated precisely. The required values of presetting can be obtained from the flow charts. All intermediate values are infinitely adjustable. The selected presetting can be read off two scales. The Oventrop double regulating and commissioning valves have two threaded ports which are equipped with the pressure test points for measuring the differential pressure.

Specifications:

Maximum working temperature: 300°F
Maximum working pressure: 300 psi
Temperature range: 15°F to 300°F

Groove connections for couplings.

Valve bodies manufactured from cast iron to ASME/ANSI B16.5 and flanged to 125 lb. standards. Valve body made of cast iron (GG 25 EN-GJL-250), hole circle of the flanged connection according to ANSI 150.

Bonnet, stem and disc made of bronze/dezincification resistant brass.
Disc with PTFE seal.
Double EPDM O-ring stem seal.

Oventrop Corporation
PO Box 789
East Granby, CT 06026
Phone: (860) 413-9173
www.oventrop-us.com

**“Hydrocontrol G”—Grooved Connection—3/4” to 12” valves
Cv Values for Various Handwheel Settings**

Presetting or Handwheel Turns	2 1/2”	3”	4”	5”	6”	8”	10”	12”
0.5	2.21	2.67	3.96	6.40	6.50	-	-	-
1.0	4.19	5.12	9.94	14.48	17.70	-	-	-
1.5	6.51	8.14	16.28	22.56	29.37	-	-	-
2.0	11.63	13.78	21.51	30.93	41.00	56.86	81.4	232.56
2.5	17.44	21.69	27.91	40.41	62.70	72.09	98.84	290.70
3.0	27.91	30.35	41.16	55.52	110.49	97.67	127.91	360.47
3.5	39.53	40.70	60.47	73.66	157.50	132.56	174.42	441.86
4.0	50.58	52.03	83.72	94.24	194.33	175.58	226.74	558.14
4.5	60.47	64.19	108.14	120.41	236.80	239.53	313.95	662.79
5.0	70.93	75.12	130.23	149.13	277.80	302.67	413.95	767.44
5.5	81.41	87.73	153.29	184.53	316.74	372.09	511.63	872.09
6.0	90.70	101.16	172.09	215.47	349.30	445.35	606.98	982.56
6.5	98.84	113.43	190.73	253.55	379.88	555.58	705.81	1069.77
7.0	104.65	124.13	208.15	283.90	413.49	592.44	793.02	1151.16
7.5	109.88	133.14	220.98	311.80	444.19	650.00	883.72	1244.19
8.0	113.95	142.09	233.72	340.70	470.12	718.60	976.74	1325.58
8.5	-	-	-	-	-	767.44	1034.88	1406.98
9.0	-	-	-	-	-	842.44	1084.88	1500.00
9.5	-	-	-	-	-	881.98	1139.53	1569.77
10.0	-	-	-	-	-	894.19	1195.35	1651.16
10.5	-	-	-	-	-	906.98	1255.81	1720.93
11.0	-	-	-	-	-	918.60	1302.33	1779.07
11.5	-	-	-	-	-	931.86	1348.84	1825.58
12.0	-	-	-	-	-	947.09	1395.35	1860.47

“Hydrocontrol” Valve Accessories



Set of 2 pressure test points
Item 106 02 81



Extension piece for pressure test points
40mm Item 168 83 95
80mm Item 106 02 95

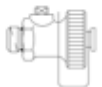

Fill and drain ball valve 1/4”
Item 106 01 91

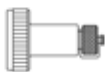

Measuring adapter
for fill and drain ball valve
Item 106 02 98



Flow meter
OV-DMC 2
Item 106 91 77

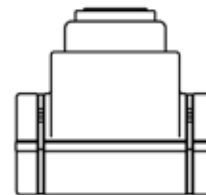

Insulation shell
for “Hydrocontrol F” & “G”

Size	Item no.
DN65 2 1/2”	106 25 86
DN80 3”	106 25 87
DN100 4”	106 25 88
DN125 5”	106 25 89
DN150 6”	106 25 90

TYPICAL SPECIFICATIONS

BALANCING VALVES

½" (DN15) – 12" (DN300)

1.0 General—Furnish and install Oventrop balancing valves, as shown on the drawings and/or schedules, to ensure the accurate balancing of all flows in the hydronic heating and cooling systems. Water balancing shall meet the specified flows with a maximum tolerance of +/- 10%. Upon completion, the balancing shall be documented in a report, which shall be submitted to the engineer for approval.

2.0 Balancing Valve Characteristics

2.1 All balancing valves shall be of the "Y" pattern globe style design. All balancing valves must offer a minimum of seven (7) full rotations of the handwheel for positioning accuracy of +/- 1%.

2.2 All balancing valves shall have documented measuring accuracy of +/- 7% within the normal setting range of the valve.

2.3 All balancing valves shall have integral self-sealing ports for measuring differential pressure and fluid temperature using standard pressure and temperature test probes. Test ports shall be located in line with the handwheel, on the same end of the valve and shall be removable to function as integral drain ports.

2.4 All balancing valves must offer 100% positive, leak-proof shutoff against the same fluid temperature and pressure ratings as the body. Minimum body ratings are 232 psi (PN16) at 300 degrees F (150 C).

2.5 All balancing valves must include a hidden memory stop to ensure return to the balanced position after shutoff. An enclosed anti-tamper lock feature shall prevent handwheel repositioning after setting.

2.6 All balancing valves ½" (DN15) through 12" (DN300) shall have digital/vernier adjustment for precise readout.

2.7 All balancing valves shall be manufactured by the company complying with international quality standard ISO 9001.

2.8 (Option) All balancing valves in sizes ½" (DN15) through 8" (DN200) shall be capable of being enclosed within factory contoured insulations with ASTM flame spread of 25 or less and a rating of E-84. Insulation "R" value shall be 4.5.

2.9 (Option) A valved hose bib fitting shall be available for installation on all ½" (DN15) through 12" (DN300) sizes. The hose bib fitting shall be capable of being placed on either side of the valve plug to accommodate draining and filling of horizontal or vertical coils.

3.0 Material Characteristics—All balancing valves in sizes ½" (DN15) through 2" (DN50) shall have bronze bodies and either solder or NPT threaded connections to match the piping system. Valve bodies in sizes 2½" (DN65) through 12" (DN300) shall be manufactured from cast iron equivalent to ASME/ANSI B16.5 and shall be flanged to 125 lb. standards. All wetted brass parts shall be alloyed to resist dezincification. No dielectric fittings shall be required for installation.

4.0 Valve Sizing—All balancing valves shall be sized to perform in a normal operation range between 25% and 100% of the full open position, at a minimum differential pressure between 1 to 3 ft. WG.

5.0 Manufacturer—Oventrop Corporation.

6.0 Warranty—Valves shall be free from material and workmanship defects for a period of 5 years from date of installation or from 5½ years from date of shipment, whichever comes first.

Oventrop reserves the right to make revisions to its products, their specifications, this bulletin, and related information without notice.

oventrop

Oventrop Corporation

PO Box 789 · 29 Kripes Road · East Granby, Connecticut 06026 · Phone 860-413-9173 · Fax 860-413-9436

oventrop

Pressure rating: 232 PSI

Temperature range: 14 °F to 212 °F

Size: 3/4"

Flow range: 0.66 to 4.6 GPM

Differential pressure range: 5 to 58 PSI

Actuator connection: M30x1.5

Supply side length: 10.5 inches

Return side length: 8 inches

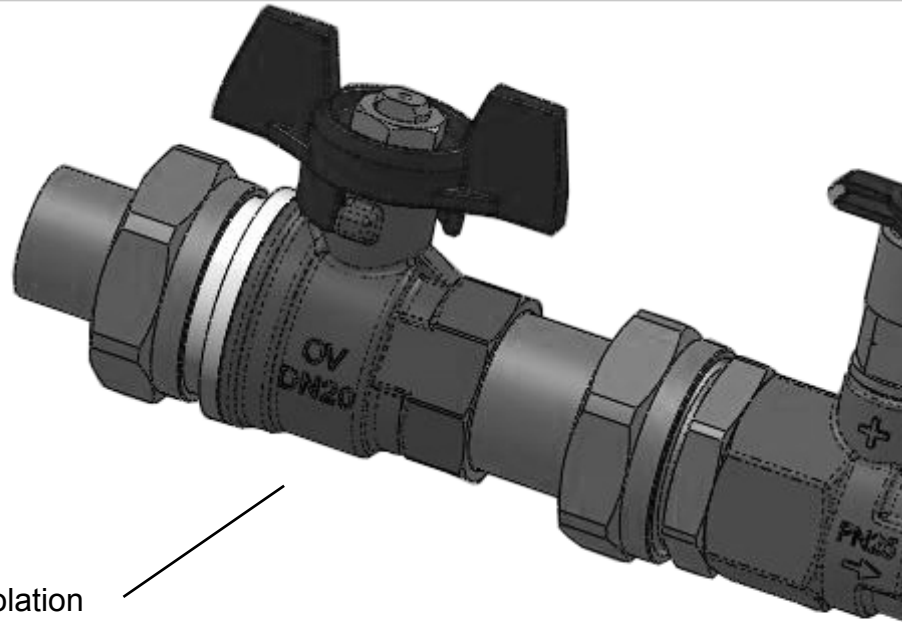

Isolation
ball valves

Fill and drain port
with shut-off ball valve

Actuator connection

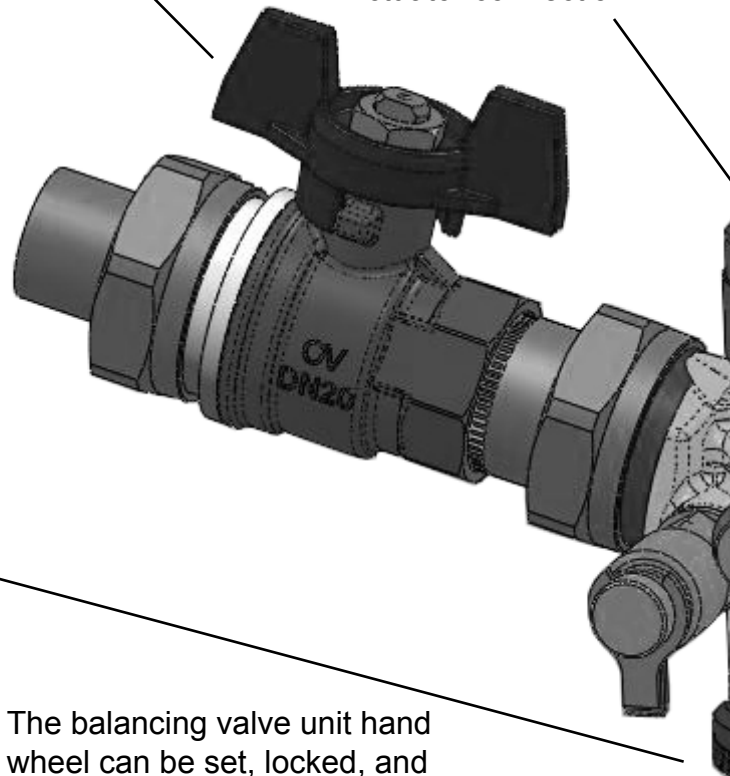

The balancing valve unit hand wheel can be set, locked, and adjusted in the field without any tools.

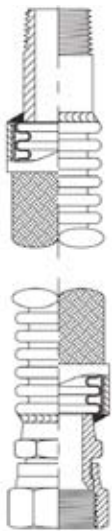

Accessory hose kits:

Lengths:
18", 24", 30", 36"

Materials:
– all stainless steel construction
– fitting welded to pipe



OV Fan Coil Package

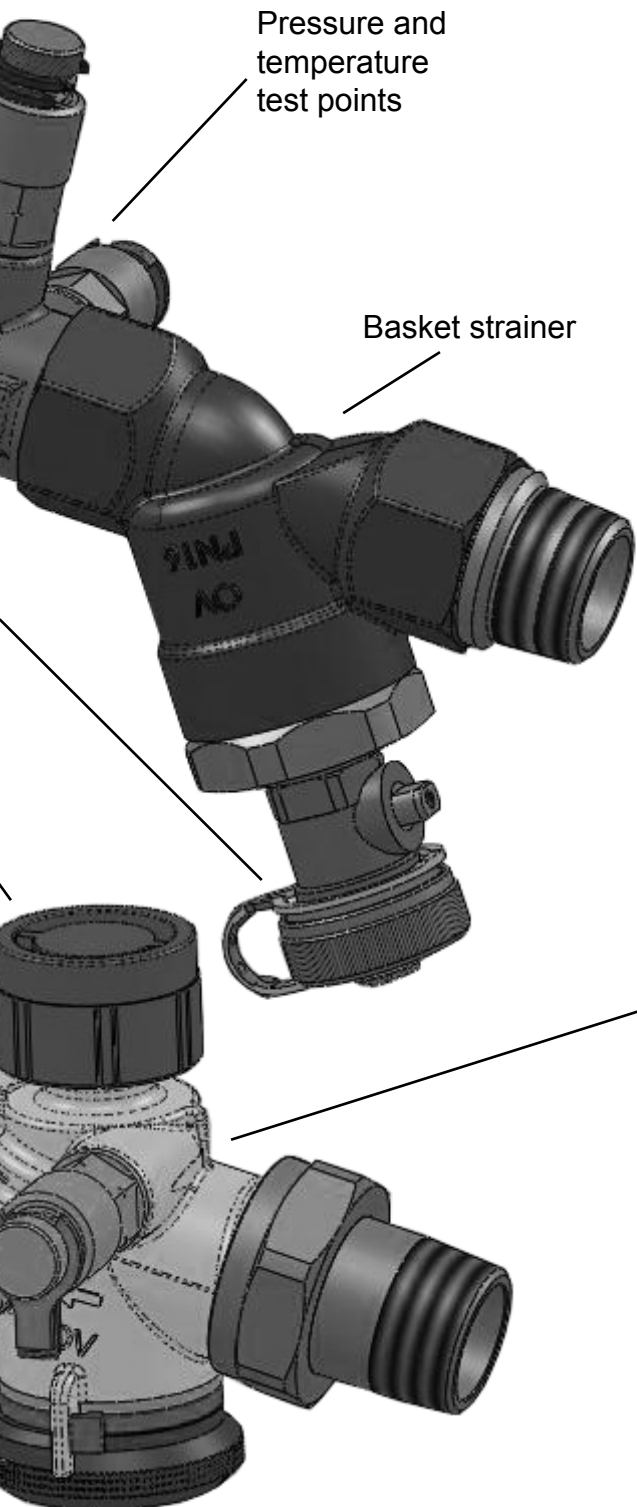

Pressure independent control valve "Cocon Q"

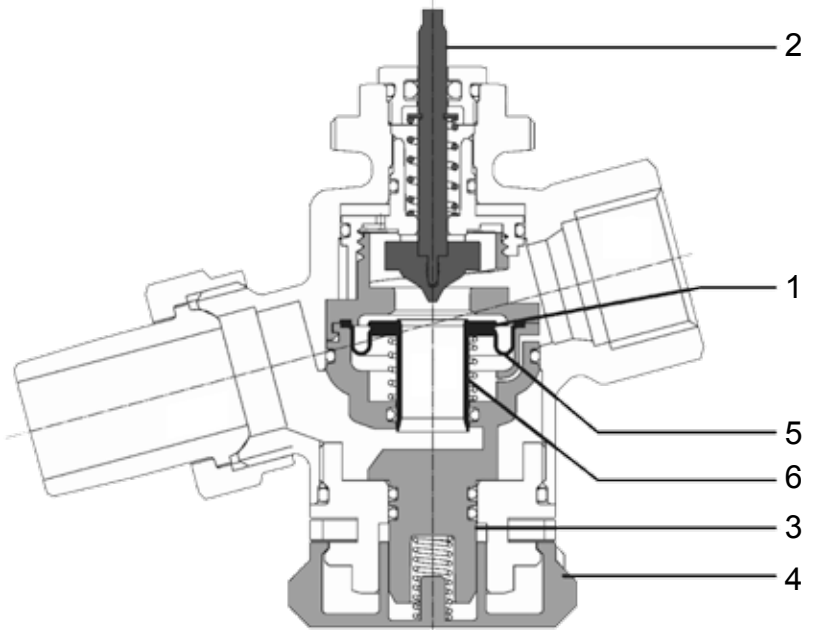

- | | |
|--------------------------|----------------|
| 1 - Diaphragm unit | 4 - Hand wheel |
| 2 - Regulating valve | 5 - Diaphragm |
| 3 - Balancing valve unit | 6 - Sleeve |

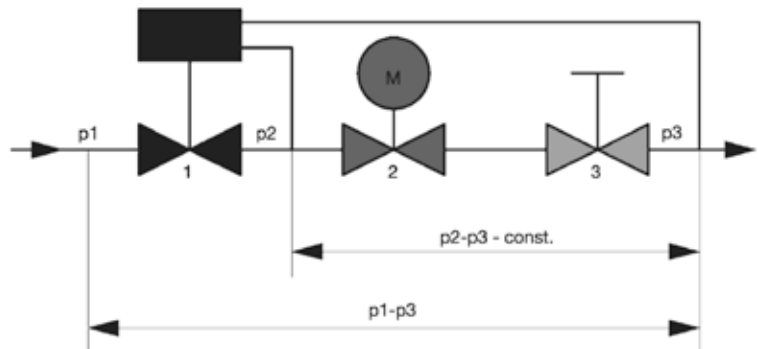

Three valves in one unit

The integrated diaphragm unit (1) acts as a differential regulator and guarantees a constant differential pressure (" p_2 " – " p_3 ") across the second valve section (regulating valve activated through the actuator or temperature controller (2) and across the third section, the on-site adjustable, automatic balancing valve unit (3).

Even at high differential pressure variations " p_1 " – " p_3 " during partial load conditions, the differential pressure " p_2 " – " p_3 " is kept at a constant level. This way, 100% valve authority is maintained.

Notes:

Oventrop Corporation
PO Box 789
East Granby, CT 06026
Phone: (860) 413-9173
www.oventrop-us.com