



Bronze double regulating and commissioning valves PN 16 "Hydrocontrol R"

Technical information

Function:

Oventrop double regulating and commissioning valves are installed in the pipework of hot water central heating systems and cooling systems as well as potable water systems (here especially in circulation pipes) and serve to achieve a hydronic balance between the various circuits of the system.

The balance is achieved by a presetting with memory position.

The required values of presetting can be obtained from the flow charts. All intermediate values are infinitely adjustable.

The selected presetting can be read off two scales (basic scale and fine adjustment scale, see illustration presetting). The Oventrop double regulating and commissioning valves have 2 threaded ports for fill and drain ball valves or pressure test points for the measurement of differential pressure. The double regulating and commissioning valves are delivered with 2 blind plugs.

The double regulating and commissioning valves may be installed in either the supply or the return pipe.

When installing the valve, it must be ensured that the direction of flow conforms with the direction of the arrow on the valve body and that the valve is installed with a minimum of 3 D (3 x nominal pipe diameter) of straight pipe at the valve inlet and of 2 D (2 x nominal pipe diameter) of straight pipe at the valve outlet.

The flow charts are valid for both cases, provided the direction of flow conforms with the arrow embossed on the valve body.

In cooling systems using mixtures of water and glycol, the correction factors related to the indicated chart values have to be taken into consideration.

Advantages:

- the location of the functioning components on one level allows a simple assembly and easy operation
- only one valve for 5 functions:
 - presetting
 - measuring
 - isolating
 - filling
 - draining
- the supply and the return pipe can be marked by use of the colour rings supplied with each valve
- low pressure loss (oblique pattern)
- infinitely adjustable presetting, exact measurement of pressure loss and flow by means of the pressure test points
- threads according to EN 10226 (BS 21), suitable for
 - fill and drain ball valve with internal stop and pressure test point with O-ring seal between valve body and test point (not additional seals required)
 - patented measuring channel led around the stem assembly to the test points ensures the best possible accuracy between the differential pressure measured at the pressure test points and the actual differential pressure of the valve (see chart indicating flow rate tolerances)



Bronze double regulating and commissioning valve PN 16 "Hydrocontrol R"

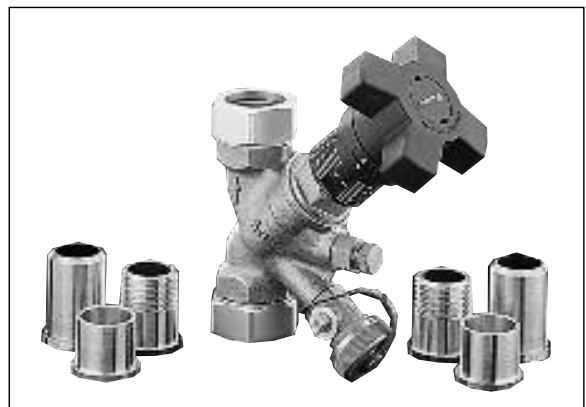

Male threads for weldable steel tailpipes
3/8" to 2"
or:
... for solder tailpipes 0.59" x to 1.65" x
or:
... for threaded tailpipes 3/8" to 1 1/2"

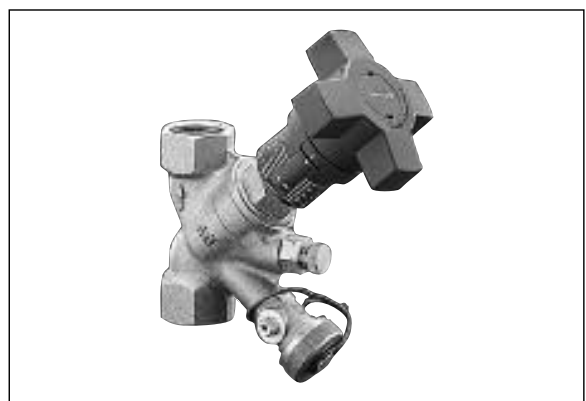

Female thread according to EN 10226 (BS 21)
3/8" to 2 1/2"

Double regulating and commissioning valve “Hydro-control R” both ports with female thread according to

Measuring technic “classic”

Tender specification:

Double regulating and commissioning valve PN 25 (pH value 6.5-10) (2 1/2": PN 16), both ports with female thread according to, between -4°F and 302°F, not suitable for steam. Colour rings for marking of supply and return pipe (except for 2 1/2"), oblique pattern with secured, infinitely adjustable fine presetting controllable at any time; optical display of the presetting depending on the position of the handwheel, valve and bonnet made of bronze (Rg 5), disc and stem made of brass resistant to de-zincification (DZR), disc with PTFE seal, maintenance-free stem seal due to double O-ring, all functioning components on one level, pressure test point and fill and drain ball valve interchangeable, installation in the supply or the return pipe.

3/8" to 2" with type approval certificate for shipbuilding. (Pressure loss charts, Cv and Zeta values, see following pages)

Double regulating and commissioning valves both ports female thread with mounted accessories set no. 2 = 2 pressure test points 1/4"

1/2"	Item no.
3/4"	106 10 04
1"	106 10 06
1 1/4"	106 10 08
1 1/2"	106 10 10
2"	106 10 12
	106 10 16

Accessories sets:

1 fill and drain ball valve	106 01 91
2 pressure test points	106 02 81
1 pressure test point	
1 fill and drain ball valve	106 03 81
1 extension for accessories sets (3.15")	106 02 95
1 extension for accessories sets (1.57")	168 82 95
1 measuring adapter	106 02 98
1 stem extension (3/8" – 2", 1.38")	168 82 96

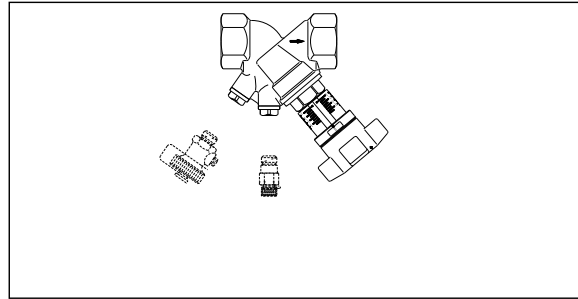

both ports female thread according to EN 10226 (BS21)
item no. Nr. 106 10 XX

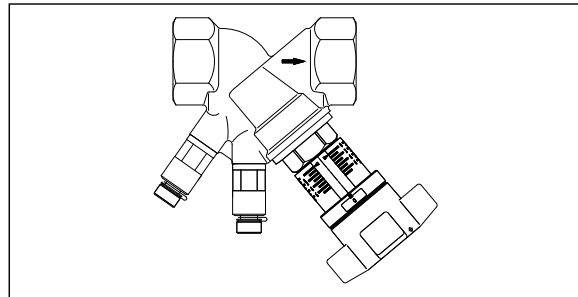

both ports female thread according to EN 10226 (BS21)
item no. 106 10 XX

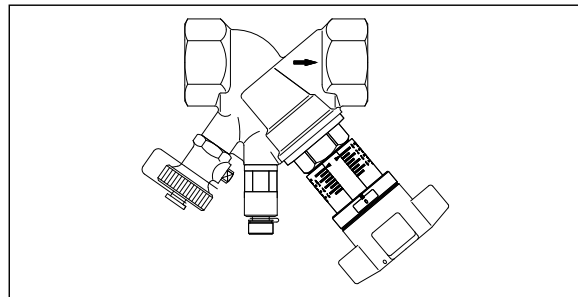

both ports female thread according to EN 10226 (BS21)
item no. 106 03 XX

Dimensions:

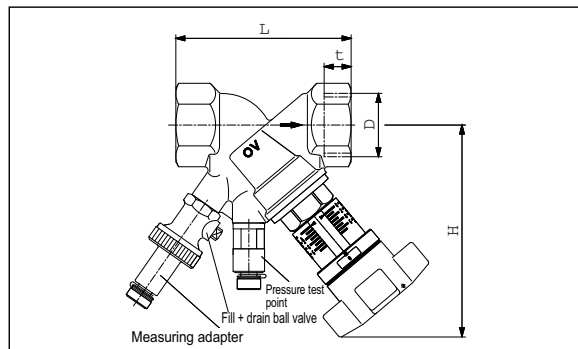

Size	D EN 10226	t	L	H
3/8"	3/8"	0.40	2.87	4.49
1/2"	1/2"	0.52	3.15	4.49
3/4"	3/4"	0.57	3.31	4.57
1"	1"	0.66	3.84	4.69
1 1/4"	1 1/4"	0.75	4.33	5.35
1 1/2"	1 1/2"	0.75	4.72	5.43
2"	2"	1.01	5.91	5.83
2 1/2"	2 1/2"	0.79	5.94	8.27

Flow charts for double regulating and commissioning valves:

3/8"

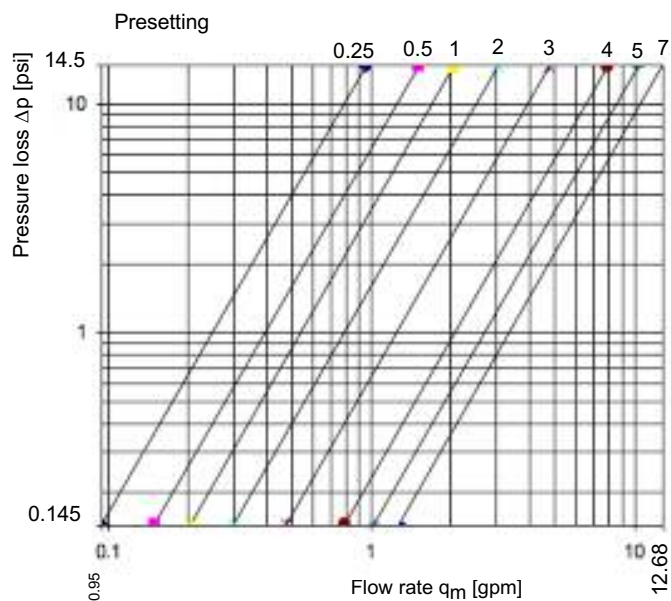

Turn	C _v -value	Zeta-value	Turn	C _v -value	Zeta-value
0.25	0.24	885			
0.5	0.4	335			
0.75	0.47	244			
1.	0.53	184	5.	2.76	6.9
1.1	0.56	169	5.1	2.81	6.7
1.2	0.58	156	5.2	2.87	6.4
1.3	0.60	144	5.3	2.93	6.1
1.4	0.63	134	5.4	2.98	6.0
1.5	0.65	124	5.5	3.02	5.8
1.6	0.67	116	5.6	3.06	5.6
1.7	0.7	108	5.7	3.09	5.5
1.8	0.73	98	5.8	3.13	5.4
1.9	0.76	92	5.9	3.16	5.3
2.	0.78	87	6.	3.20	5.2
2.1	0.81	80	6.1	3.22	5.1
2.2	0.85	73	6.2	3.24	5.0
2.3	0.88	68	6.3	3.27	4.9
2.4	0.92	63	6.4	3.29	4.9
2.5	0.97	57	6.5	3.30	4.8
2.6	1.01	52	6.6	3.31	4.8
2.7	1.06	47	6.7	3.33	4.8
2.8	1.12	42	6.8	3.34	4.7
2.9	1.20	37	6.9	3.34	4.7
3.	1.28	32	7.	3.35	4.7
3.1	1.35	29			
3.2	1.43	26			
3.3	1.50	23			
3.4	1.58	21			
3.5	1.65	19			
3.6	1.73	18			
3.7	1.81	16			
3.8	1.88	15			
3.9	1.97	14			
4.	2.05	13			
4.1	2.12	12			
4.2	2.19	11			
4.3	2.26	10			
4.4	2.33	9.8			
4.5	2.40	9.2			
4.6	2.47	8.7			
4.7	2.55	8.1			
4.8	2.62	7.7			
4.9	2.69	7.3			

1/2"

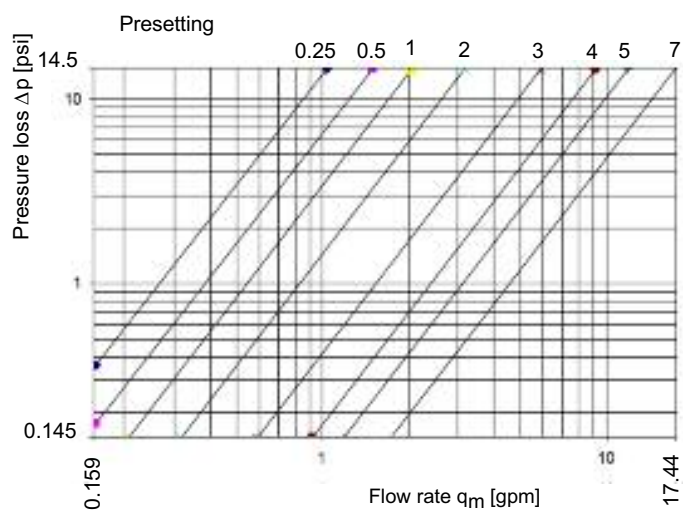

Turn	C _v -value	Zeta-value	Turn	C _v -value	Zeta-value
0.25	0.27	1981			
0.5	0.40	906			
0.75	0.47	655			
1.	0.53	495	5.	3.14	14
1.1	0.56	455	5.1	3.22	14
1.2	0.58	419	5.2	3.30	13
1.3	0.60	388	5.3	3.40	12
1.4	0.64	346	5.4	3.48	12
1.5	0.66	323	5.5	3.56	11
1.6	0.70	291	5.6	3.64	11
1.7	0.73	264	5.7	3.72	10
1.8	0.77	241	5.8	3.80	9.8
1.9	0.80	220	5.9	3.88	9.4
2.	0.84	202	6.	3.95	9.1
2.1	0.88	181	6.1	4.03	8.7
2.2	0.93	164	6.2	4.12	8.4
2.3	0.99	145	6.3	4.20	8.0
2.4	1.06	127	6.4	4.27	7.8
2.5	1.14	109	6.5	4.33	7.6
2.6	1.22	95	6.6	4.37	7.4
2.7	1.30	84	6.7	4.41	7.3
2.8	1.40	73	6.8	4.44	7.2
2.9	1.48	65	6.9	4.48	7.1
3.	1.56	58	7.	4.51	7
3.1	1.64	53			
3.2	1.72	48			
3.3	1.80	44			
3.4	1.88	40			
3.5	1.98	36			
3.6	2.06	33			
3.7	2.14	31			
3.8	2.22	29			
3.9	2.30	27			
4.	2.38	25			
4.1	2.47	23			
4.2	2.53	22			
4.3	2.60	21			
4.4	2.69	20			
4.5	2.77	18			
4.6	2.84	18			
4.7	2.92	17			
4.8	2.99	16			
4.9	3.06	15			

Flow charts for double regulating and commissioning valves:

3/4"

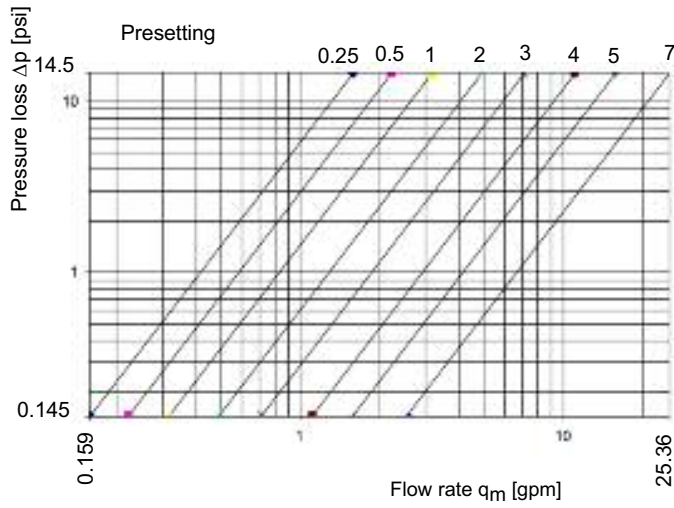

Turn	C _v -value	Zeta-value	Turn	C _v -value	Zeta-value
0.25	0.41	2841			
0.5	0.58	1392			
0.75	0.73	877			
1.	0.84	671	5.	4.24	26
1.1	0.88	603	5.1	4.40	24
1.2	0.94	530	5.2	4.53	23
1.3	0.99	482	5.3	4.67	22
1.4	1.03	439	5.4	4.83	20
1.5	1.08	402	5.5	4.97	19
1.6	1.13	370	5.6	5.12	17
1.7	1.17	341	5.7	5.26	17
1.8	1.22	316	5.8	5.41	16
1.9	1.28	288	5.9	5.55	15
2.	1.33	268	6.	5.69	15
2.1	1.37	250	6.1	5.84	14
2.2	1.42	234	6.2	5.99	13
2.3	1.47	219	6.3	6.14	12
2.4	1.51	206	6.4	6.23	12
2.5	1.57	191	6.5	6.33	12
2.6	1.63	178	6.6	6.40	12
2.7	1.69	166	6.7	6.47	11
2.8	1.74	155	6.8	6.52	11
2.9	1.80	145	6.9	6.58	11
3.	1.86	136	7.	6.64	11
3.1	1.93	126			
3.2	2.02	115			
3.3	2.12	105			
3.4	2.24	93			
3.5	2.37	84			
3.6	2.50	75			
3.7	2.62	69			
3.8	2.74	62			
3.9	2.87	57			
4.	3.00	52			
4.1	3.13	48			
4.2	3.26	44			
4.3	3.38	41			
4.4	3.50	38			
4.5	3.63	36			
4.6	3.76	33			
4.7	3.88	31			
4.8	4.00	29			
4.9	4.13	28			

1"

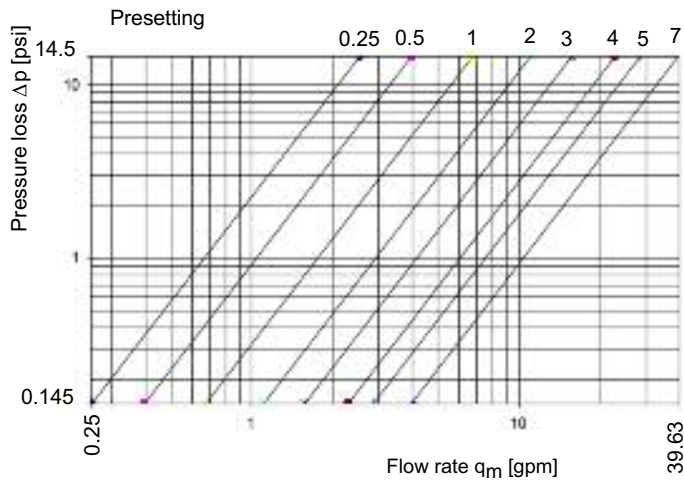

Turn	C _v -value	Zeta-value	Turn	C _v -value	Zeta-value
0.25	0.66	2774			
0.5	1.08	1042			
0.75	1.42	605			
1.	1.77	390	5.	7.81	20
1.1	1.91	335	5.1	7.95	19
1.2	2.05	291	5.2	8.09	19
1.3	2.17	258	5.3	8.23	18
1.4	2.30	230	5.4	8.37	17
1.5	2.42	208	5.5	8.51	17
1.6	2.53	190	5.6	8.65	16
1.7	2.65	173	5.7	8.79	16
1.8	2.77	159	5.8	8.93	15
1.9	2.88	147	5.9	9.07	15
2.	3.00	135	6.	9.20	14
2.1	3.10	126	6.1	9.33	14
2.2	3.22	117	6.2	9.44	14
2.3	3.34	109	6.3	9.56	13
2.4	3.47	101	6.4	9.66	13
2.5	3.59	94	6.5	9.78	13
2.6	3.72	88	6.6	9.90	12
2.7	3.85	82	6.7	10.01	12
2.8	3.99	77	6.8	10.13	12
2.9	4.14	71	6.9	10.23	12
3.	4.29	66	7.	10.34	11
3.1	4.44	62			
3.2	4.60	57			
3.3	4.78	53			
3.4	4.95	50			
3.5	5.14	46			
3.6	5.31	43			
3.7	5.49	40			
3.8	5.66	38			
3.9	5.84	36			
4.	6.00	34			
4.1	6.19	32			
4.2	6.36	30			
4.3	6.55	28			
4.4	6.73	27			
4.5	6.92	25			
4.6	7.09	24			
4.7	7.28	23			
4.8	7.47	22			
4.9	7.64	21			

Flow charts for double regulating and commissioning valves:

1 1/4"

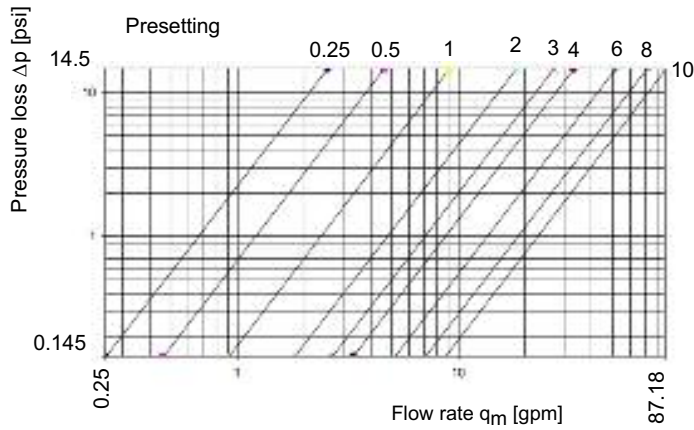

Turn	C _v -value	Zeta-value	Turn	C _v -value	Zeta-value	Turn	C _v -value	Zeta-value
0.25	0.66	8174						
0.5	1.20	2503						
0.75	1.78	1135						
1.	2.40	626	5.	11.27	28	9	21.14	8.0
1.1	2.56	549	5.1	11.51	27	9.1	21.34	7.9
1.2	2.73	481	5.2	11.74	26	9.2	21.51	7.8
1.3	2.93	418	5.3	11.98	25	9.3	21.69	7.6
1.4	3.14	364	5.4	12.21	24	9.4	21.86	7.5
1.5	3.37	316	5.5	12.44	23	9.5	22.01	7.4
1.6	3.60	276	5.6	12.67	22	9.6	22.15	7.3
1.7	3.86	241	5.7	12.91	22	9.7	22.27	7.2
1.8	4.13	211	5.8	13.14	21	9.8	22.38	7.2
1.9	4.40	186	5.9	13.37	20	9.9	22.50	7.1
2.	4.67	164	6.	13.60	19	10.	22.62	7.0
2.1	4.94	147	6.1	13.84	19			
2.2	5.21	132	6.2	14.09	18			
2.3	5.44	121	6.3	14.36	17			
2.4	5.67	112	6.4	14.62	17			
2.5	5.91	103	6.5	14.88	16			
2.6	6.10	96	6.6	15.12	16			
2.7	6.34	89	6.7	15.37	15			
2.8	6.57	83	6.8	15.64	15			
2.9	6.78	78	6.9	15.91	14			
3.	6.98	74	7.	16.17	14			
3.1	7.17	70	7.1	16.43	13			
3.2	7.38	66	7.2	16.69	13			
3.3	7.58	62	7.3	16.94	13			
3.4	7.79	59	7.4	17.21	12			
3.5	7.97	57	7.5	17.47	12			
3.6	8.14	54	7.6	17.72	11			
3.7	8.33	52	7.7	17.98	11			
3.8	8.52	49	7.8	18.23	11			
3.9	8.71	47	7.9	18.49	11			
4.	8.88	45	8.	18.73	10			
4.1	9.13	43	8.1	18.99	10			
4.2	9.36	41	8.2	19.24	9.7			
4.3	9.59	39	8.3	19.50	9.4			
4.4	9.83	37	8.4	19.74	9.2			
4.5	10.06	35	8.5	19.97	9.0			
4.6	10.29	34	8.6	20.19	8.8			
4.7	10.52	32	8.7	20.34	8.6			
4.8	10.76	31	8.8	20.67	8.4			
4.9	11.01	30	8.9	20.91	8.2			

1 1/2"

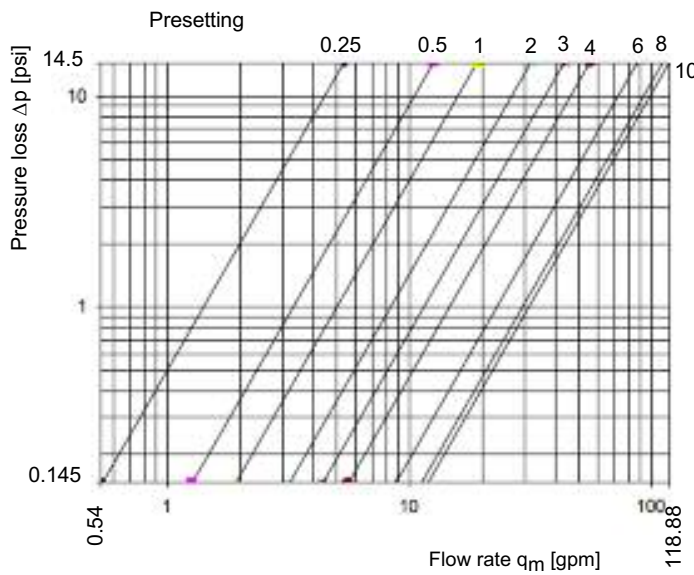

Turn	C _v -value	Zeta-value	Turn	C _v -value	Zeta-value	Turn	C _v -value	Zeta-value
0.25	1.40	3390						
0.5	3.09	690						
0.75	4.12	390						
1.	4.80	286	5.	17.74	21	9	30.34	7.2
1.1	5.19	245	5.1	18.20	20	9.1	30.51	7.1
1.2	5.56	214	5.2	18.72	19	9.2	30.67	7.0
1.3	5.93	188	5.3	19.24	18	9.3	30.84	6.9
1.4	6.30	166	5.4	19.71	17	9.4	31.00	6.9
1.5	6.67	148	5.5	20.17	16	9.5	31.16	6.8
1.6	7.05	133	5.6	20.70	15	9.6	31.33	6.7
1.7	7.42	120	5.7	21.16	15	9.7	31.49	6.7
1.8	7.79	109	5.8	21.69	14	9.8	31.65	6.6
1.9	8.16	99	5.9	22.15	13	9.9	31.83	6.5
2.	8.53	91	6.	22.62	13	10.	31.99	6.4
2.1	8.86	84	6.1	22.97	13			
2.2	9.17	78	6.2	23.31	12			
2.3	9.49	73	6.3	23.66	12			
2.4	9.80	69	6.4	24.01	11			
2.5	10.12	64	6.5	24.36	11			
2.6	10.43	61	6.6	24.71	10			
2.7	10.74	57	6.7	25.06	10			
2.8	11.06	54	6.8	25.41	10			
2.9	11.36	51	6.9	25.76	9.9			
3.	11.65	49	7.	26.10	9.7			
3.1	11.92	46	7.1	26.40	9.5			
3.2	12.21	44	7.2	26.69	9.3			
3.3	12.48	42	7.3	26.92	9.1			
3.4	12.76	41	7.4	27.15	9.0			
3.5	13.02	39	7.5	27.47	8.7			
3.6	13.29	37	7.6	27.76	8.6			
3.7	13.56	36	7.7	28.02	8.4			
3.8	13.84	34	7.8	28.31	8.2			
3.9	14.10	33	7.9	28.58	8.1			
4.	14.37	32	8.	28.86	7.9			
4.1	14.71	31	8.1	29.01	7.8			
4.2	15.06	29	8.2	29.15	7.7			
4.3	15.41	28	8.3	29.30	7.7			
4.4	15.72	27	8.4	29.44	7.6			
4.5	16.05	26	8.5	29.59	7.5			
4.6	16.40	25	8.6	29.73	7.5			
4.7	16.74	24	8.7	29.88	7.4			
4.8	17.09	23	8.8	30.03	7.3			
4.9	17.42	22	8.9	30.19	7.2			

Flow charts for double regulating and commissioning valves:

2"

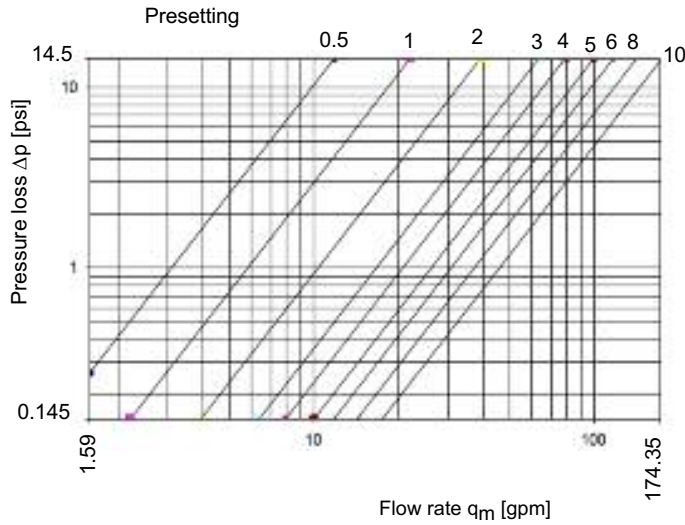

Turn	C _v -value	Zeta-value	Turn	C _v -value	Zeta-value	Turn	C _v -value	Zeta-value
0.5	3.13	1743						
0.75	4.85	726						
1.	5.88	493	5.	26.66	24	9.	42.65	9.4
1.1	6.40	417	5.1	27.03	23	9.1	43.02	9.2
1.2	6.92	356	5.2	27.41	23	9.2	43.31	9.1
1.3	7.38	313	5.3	27.79	22	9.3	43.60	9.0
1.4	7.85	277	5.4	28.14	22	9.4	43.90	8.9
1.5	8.31	247	5.5	28.49	21	9.5	44.13	8.8
1.6	8.78	221	5.6	28.84	21	9.6	44.36	8.7
1.7	9.24	200	5.7	29.24	20	9.7	44.59	8.6
1.8	9.77	179	5.8	29.59	19	9.8	44.77	8.5
1.9	10.23	163	5.9	30.00	19	9.9	44.94	8.5
2.	10.66	150	6.	30.04	19			
2.1	11.22	135	6.1	30.76	18	10.	45.09	8.4
2.2	11.80	122	6.2	31.16	18			
2.3	12.38	111	6.3	31.51	17			
2.4	12.97	101	6.4	31.92	17			
2.5	13.55	93	6.5	32.27	16			
2.6	14.13	85	6.6	32.62	16			
2.7	14.71	79	6.7	33.02	16			
2.8	15.35	72	6.8	33.43	15			
2.9	15.93	67	6.9	33.84	15			
3.	16.55	62	7.	34.20	15			
3.1	17.03	59	7.1	34.59	14			
3.2	17.56	55	7.2	35.00	14			
3.3	18.02	53	7.3	35.35	14			
3.4	18.55	50	7.4	35.76	13			
3.5	19.01	47	7.5	36.16	13			
3.6	19.53	45	7.6	36.57	13			
3.7	20.06	42	7.7	36.98	12			
3.8	20.52	40	7.8	37.33	12			
3.9	21.05	39	7.9	37.73	12			
4.	21.51	37	8.	38.06	12			
4.1	22.09	35	8.1	38.55	11			
4.2	22.62	33	8.2	39.01	11			
4.3	23.08	32	8.3	39.42	11			
4.4	23.60	31	8.4	39.88	11			
4.5	24.07	29	8.5	40.35	10			
4.6	24.59	28	8.6	40.81	10			
4.7	25.12	27	8.7	41.28	10			
4.8	25.64	26	8.8	41.74	9.8			
4.9	26.16	25	8.9	42.21	9.6			

2 1/2"

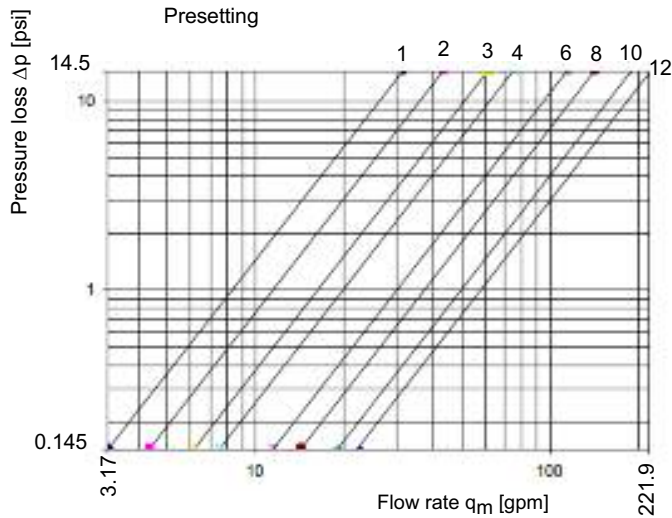

Turn	C _v -value	Zeta-value	Turn	C _v -value	Zeta-value	Turn	C _v -value	Zeta-value
1.	8.14	705	5.	25.58	71	9.	40.72	28
1.1	8.49	648	5.1	26.05	69	9.1	41.29	27
1.2	8.84	598	5.2	26.51	66	9.2	41.86	27
1.3	9.19	554	5.3	26.98	64	9.3	42.44	26
1.4	9.53	514	5.4	27.44	62	9.4	43.02	25
1.5	9.88	478	5.5	27.91	60	9.5	43.60	25
1.6	10.23	446	5.6	28.37	58	9.6	44.19	24
1.7	10.58	417	5.7	28.84	56	9.7	44.77	23
1.8	10.93	391	5.8	29.30	54	9.8	45.35	23
1.9	11.28	367	5.9	29.77	53	9.9	45.93	22
2.	11.63	345	6.	30.23	51	10.	46.51	22
2.1	12.09	319	6.1	30.58	50	10.1	47.09	21
2.2	12.56	296	6.2	30.93	49	10.2	47.67	21
2.3	13.02	275	6.3	31.28	48	10.3	48.26	20
2.4	13.49	257	6.4	31.63	47	10.4	48.84	20
2.5	13.95	240	6.5	31.98	46	10.5	49.42	19
2.6	14.42	225	6.6	32.21	45	10.6	50.00	19
2.7	14.88	211	6.7	32.44	44	10.7	50.58	18
2.8	15.35	198	6.8	32.67	44	10.8	51.16	18
2.9	15.81	187	6.9	32.91	43	10.9	51.74	17
3.	16.28	176	7.	33.14	43	11.	52.33	17
3.1	16.63	169	7.1	33.14	42	11.1	52.91	17
3.2	16.98	162	7.2	33.84	41	11.2	53.49	16
3.3	17.33	156	7.3	34.19	40	11.3	54.07	16
3.4	17.67	150	7.4	34.53	39	11.4	54.65	16
3.5	18.02	144	7.5	34.88	38	11.5	55.23	15
3.6	18.37	138	7.6	35.35	37	11.6	55.81	15
3.7	18.72	133	7.7	35.81	36	11.7	56.40	15
3.8	19.07	128	7.8	36.28	35	11.8	56.98	14
3.9	19.42	124	7.9	36.74	35	11.9	57.56	14
4.	19.77	120	8.	37.21	34	12.	58.14	14
4.1	20.35	113	8.1	37.56	33			
4.2	20.93	107	8.2	37.91	33			
4.3	21.51	101	8.3	38.26	32			
4.4	22.09	96	8.4	38.60	31			
4.5	22.67	91	8.5	38.95	31			
4.6	23.26	86	8.6	39.30	30			
4.7	23.84	82	8.7	39.65	30			
4.8	24.42	78	8.8	40.00	29			
4.9	25.00	75	8.9	40.35	29			

Isolating and orifice valve "Hydrocontrol A" without presetting - flow tolerances for double regulating and commissioning valves both ports with connections for measuring technic "classic"

Dimensions identical to those of double regulating and commissioning valves **with** presetting

Tender specification:

Isolating and orifice valve PN 25, both ports with female thread according to EN 10226 (BS 21) and isolating and orifice valve PN 16, both ports with male thread and collar nut for weldable, solder and threaded tailpipes, flat sealing, between -4°F and 302°F, not suitable for steam, colour rings for marking of supply and return pipe, oblique pattern. Valve body and bonnet made of brass (Rg 5), disc and stem made of brass resistant to dezincification (DZR), disc with PTFE soft seal, maintenance-free stem seal due to double O-ring. Installation in the supply or the return pipe.

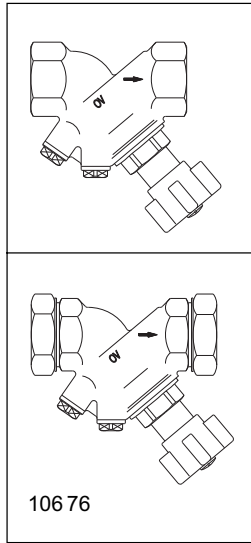

Bronze isolating and orifice valve with female thread (threaded ports for accessories closed with blind plugs)

(3/8")	106 75 03
(1/2")	106 75 04
(3/4")	106 75 06
(1")	106 75 08
(1 1/4")	106 75 10
(1 1/2")	106 75 12
(2")	106 75 16

Bronze isolating and orifice valve with male thread and collar nut (threaded ports for accessories closed with blind plugs)

(3/8")	106 76 03
(1/2")	106 76 04
(3/4")	106 76 06
(1")	106 76 08
(1 1/4")	106 76 10
(1 1/2")	106 76 12
(2")	106 76 16

Accessories:
1 fill and drain ball valve 1060191

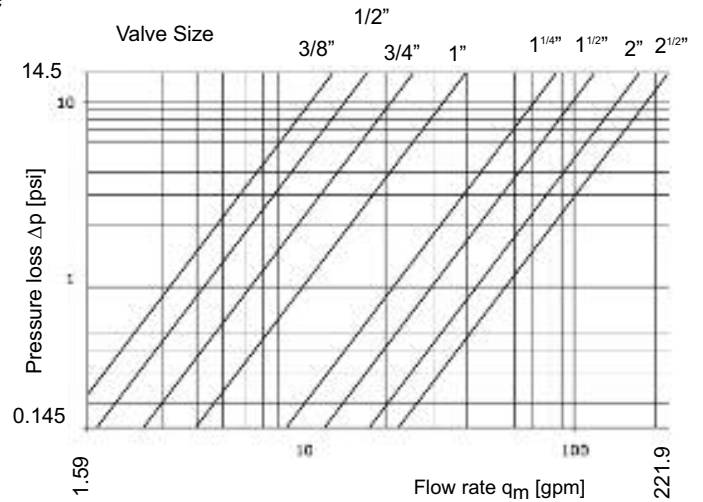

Tailpipe sets:

2 weldable tailpipes

3/8"	106 05 91
1/2"	106 05 92
3/4"	106 05 93
1"	106 05 94
1 1/4"	106 05 95
1 1/2"	106 05 96
2"	106 05 97

2 solder tailpipes

0.59"	1/2"	106 10 92
0.71"	3/4"	106 10 93
0.87"	3/4"	106 10 94
1.10"	1"	106 10 95
1.38"	1 1/4"	106 10 96
1.65"	1 1/2"	106 10 97

2 tailpipes with male thread

3/8"	106 14 91
1/2"	106 14 92
3/4"	106 14 93
1"	106 14 94
1 1/4"	106 14 95
1 1/2"	106 14 96

2 tailpipes with female thread

1/2"	101 93 64
3/4"	101 93 66
1"	106 13 94
1 1/4"	106 13 95

Flow tolerances depending on the presetting (double regulating and commissioning valves item no. 106 01/02/03/05):

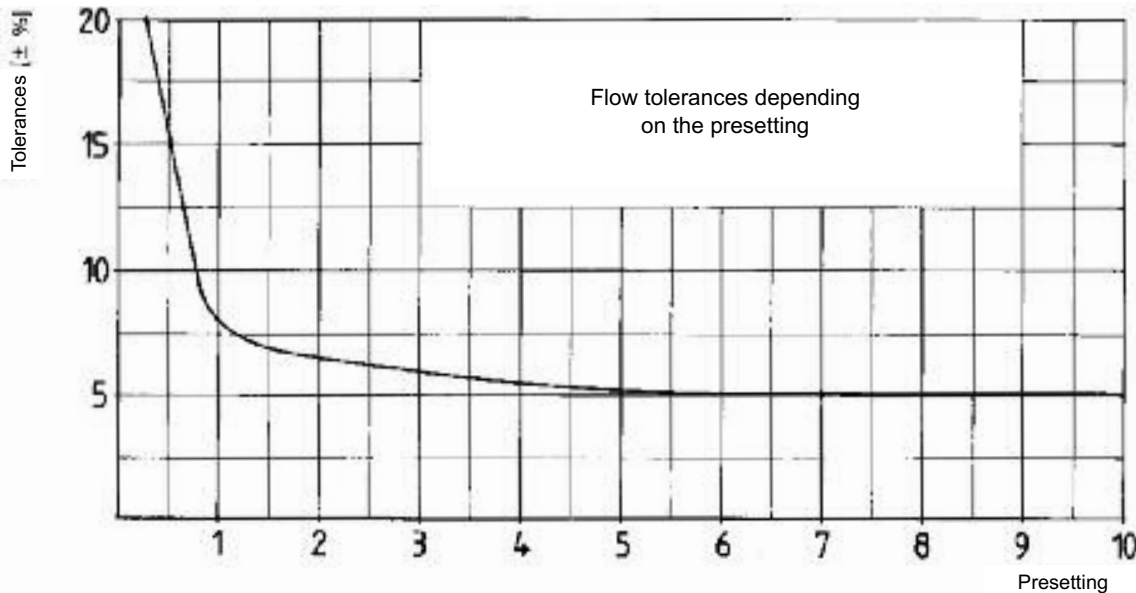

Insulation shells:

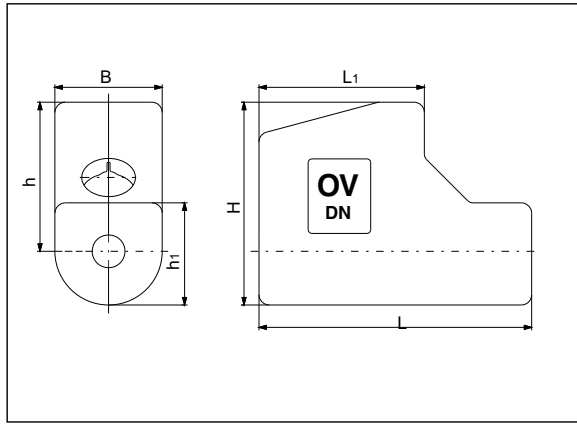

Tender specification:

Insulation shells made of Polyurethane, double shells with tongue-and-groove fitting.

Item nos.:

3/8"	106 00 81
1/2"	106 00 81
3/4"	106 00 82
1"	106 00 83
1 1/4"	106 00 84
1 1/2"	106 00 85
2"	106 00 86

Dimensions:

Size	B	L	L ₁	H	h	h ₁
1/2"	2.83	7.2	4.37	5.35	3.94	2.72
3/4"	3.15	7.68	4.8	5.63	4.06	3.03
1"	3.46	9.57	5.55	5.94	4.21	3.35
1 1/4"	4.02	10	5.87	6.77	4.76	3.82
1 1/2"	4.29	9.84	5.94	7.28	5.16	4.13
2"	4.92	10.87	6.42	8.23	5.79	4.72

Presetting:

- The value of presetting of the valve is set by turning the handwheel.
- The display of the basic setting is shown by the longitudinal scale together with the sliding indicator. Each turn of the handwheel is represented by a line on the longitudinal scale.
- The display of the fine setting is shown by the peripheral scale on the handwheel together with the marking. The subdivisions of the peripheral scale correspond to 1/10th of a turn of the handwheel.
- Limitation of the set value of presetting by turning the inner adjustment stem clockwise until it seats. This can be done by using the long end of a 3 mm Allen key.

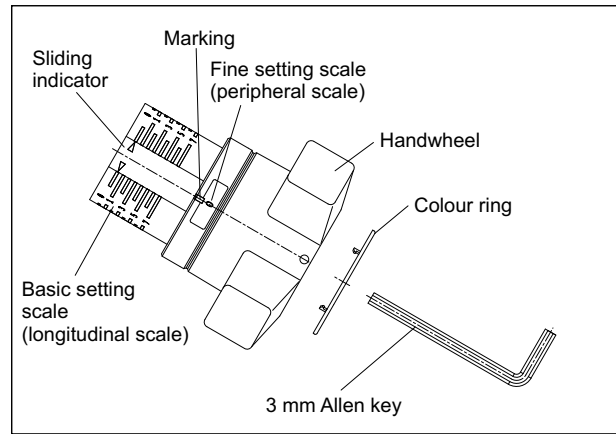

Marking of the flow and return pipe:

Clip one of the colour rings (red = supply, blue = return) supplied with each valve onto the handwheel.

Installation advice:

Oventrop double regulating and commissioning valves serve to achieve the hydronic balance between the various circuits of a system. It is therefore to be observed that the direction

of flow conforms with the arrow on the valve body. The flow tolerance is ± 5%. If installed against the flow, an increase in the flow rate of 1-3%, related to the chart value, must be considered.

Correction factor for mixtures of water and glycol:

When antifreeze liquids are added to the heating water, the values given in the chart must be multiplied by the correction factor f.

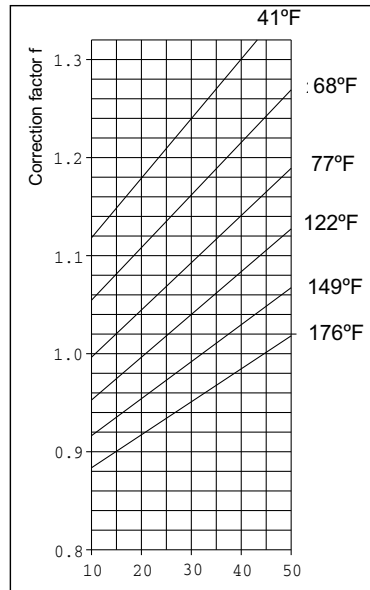

Weight proportion of ethylene glycol [%]

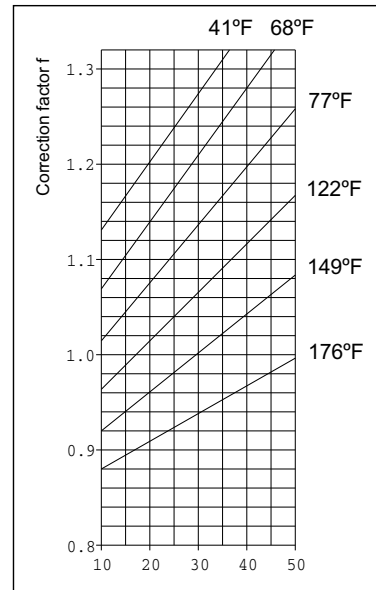

Weight proportion of propylene glycol [%]

Measuring and regulation

Oventrop flow-meter "OV-DMC 2" (with memory and microprocessor)

featuring numerous functions and a wide range of applications:

- flow rate indication (indication in m³/h, l/s, l/min, l/h, gal/min)
- differential pressure measuring (indication in mbar, kPa, PSI, mm WG, m WG)
- temperature measuring (indication in °C or °F)
- presetting Arriving at the presetting value based on the measured differential pressure, the given flowrate and the valve size.

The characteristic lines of all Oventrop regulating valves Sizes 3/8" – 12" are memorised in the flow-meter.

With the use of a respective kv value, it is possible to carry out measurements on valves of other manufacturers.

(For practical use of the "OV-DMC 2", special operating instructions are available.)



Flow-meter "OV-DMC 2", item no. 106 91 77 with "Hydrocontrol R"

Subject to technical modification without notice.

Product group 3
ti 19-1/10/MW
Edition 2007

Printed on paper free
from
chlorine bleaching.

Oventrop Corporation
P.O. Box 789
29 Kripes Road
East Granby, CT 06026
P:(860) 413-9173
F:(860) 413-9436
Email:oventrop@comcast.net
Internet:www.oventrop-na.net